



CAUTION: This stabilized antenna system is designed to be used with transmit/receive equipment manufactured by others. Refer to the documentation supplied by the manufacturer which will describe potential hazards, including exposure to RF radiation, associated with the improper use of the transmit/receive equipment. Note that the transmit/receive equipment will operate independently of the stabilized antenna system. **Prior to work on the stabilized antenna system, the power to the transmit/receive system must be locked out and tagged.**

When the transmit/receive system is in operation, no one should be allowed **anywhere within the radiated beam** being emitted from the reflector.

The ultimate responsibility for safety rests with the facility operator and the individuals who work on the system.

**INSTALLATION AND OPERATION
MANUAL FOR SEA TEL BROADBAND-AT-SEA
TRANSMIT / RECEIVE SYSTEM
MODEL: 4006-33 CO-POL OR CROSS-POL**

Sea Tel, Inc.
4030 Nelson Avenue
Concord, CA 94520
Tel: (925) 798-7979
Fax: (925) 798-7986
Email: seatel@seatel.com
Web: www.seatel.com

November 20, 2007



Sea Tel Europe
Unit 1, Orion Industrial Centre
Wide Lane, Swaythling
Southampton, UK S0 18 2HJ
Tel: 44 (0)23 80 671155
Fax: 44 (0)23 80 671166
Email: europe@seatel.com
Web: www.seatel.com

Document. No. 127374
Rev A



Sea Tel Marine Stabilized Antenna systems are manufactured in the United States of America.



Sea Tel is an ISO 9001:2000 registered company. Certificate Number 19.2867 was issued August 12, 2005. Sea Tel was originally registered on November 09, 1998.



The Series 06 Family of Marine Stabilized Antenna Pedestals with DAC-2200 Antenna Control Unit complies with the requirements of European Norms and European Standards EN 60945 (1997) and prETS 300 339 (1998-03). Sea Tel European Union Declaration of Conformity for this equipment is contained in this manual.

Copyright Notice

All Rights Reserved. The information contained in this document is proprietary to Sea Tel, Inc.. This document may not be reproduced or distributed in any form without the consent of Sea Tel, Inc. The information in this document is subject to change without notice.

Copyright © 2007 Sea Tel, Inc.

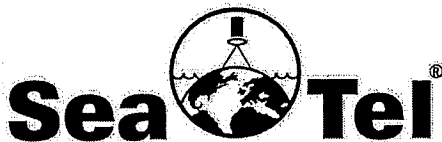

Sea Tel
Marine Stabilized Antenna Systems
European Union Declaration of Conformity
Marine Navigational Equipment

The EU Directives Covered by this Declaration:

European Norms and European Standards EN 60945 (1997) and prETS 300 339 (1998-03).

The Product Covered by this Declaration:

Series 06 Family of Marine Stabilized Antenna Pedestals with DAC-2200 Antenna Control Unit.

The Basis on which Conformity is being Declared:

The product identified above complies with the requirements of the above EU Directives by meeting the following standards:

* EN 60945 (1997) "Marine Navigational Equipment - General Requirements – Methods of Testing and Required Test Results":

- Conducted Emissions (Clause 9.1 & 9.2)
- Radiated Emissions (Clause 9.1 & 9.3)
- Conducted Low Frequency (Audio) Interference (Clause 10.1 & 10.2)
- Conducted Radio Frequency Interference (Clause 10.3) & IEC 1000-4-6 (1995)
- Radiated Radio Frequencies (Clause 10.4) & IEC 1000-4-3 (1995)
- Fast Transients on Signal/Control Lines (Clause 10.5) & IEC 1000-4-4 (1995)
- Surges on AC Power Lines (Clause 10.6) & IEC 1000-4-5 (1995)
- Power Supply Short-Term Variation (Clause 10.7)
- Power Supply Failure (Clause 10.8)
- Electrostatic Discharge (Clause 10.9) & IEC 1000-4-2 (1995)
- Compass Safe Distance (Clause 11.2, Measurement Only)

* prETS 300 339 (1998-03) Electromagnetic compatibility and Radio spectrum Matters (ERM); General ElectroMagnetic Compatibility (EMC) for Radio Communications Equipment.

- RF Radiated Field Immunity (Clause 9.3)
- RF Common Mode Immunity (Clause 9.4, 9.5 & 9.6)

The technical documentation required to demonstrate that this product meets the requirements of the EMC Directive has been compiled by the signatory below and is available for inspection by the relevant enforcement authorities. The CE mark was first applied to this equipment in 2005.

Authority: Mr. J. Patrick Matthews
President

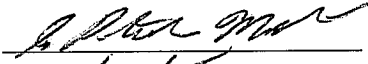
Signature: 
Date: 7/27/05

Attention

The attention of the specifier, purchaser, installer or user is drawn to special measures and limitations to use which must be observed when the product is taken into service to maintain compliance with the above directives. Details of these special measures and limitations are in the product manual.

RF Transmit and Receive equipment components (Radio Packages, Drivers, HPAs and LNCs) or TVRO LNBs which are mounted on the Marine Stabilized Antenna Pedestal must be CE marked separately by the manufacturer of those components.



Sea Tel, Inc.
4030 Nelson Ave.
Concord, CA. 94520
Phone: (925) 798-7979
Fax: (925) 798-7986



Doc 124593-A

Revision History

REV	ECO#	Date	Description	By
A	N/A	November 19, 2007	Production Release.	MDN

1. INTRODUCTION.....	1-1
1.1. GENERAL SYSTEM DESCRIPTION.....	1-1
1.2. PURPOSE	1-1
1.3. SYSTEM COMPONENTS.....	1-1
1.4. GENERAL SCOPE OF THIS MANUAL	1-2
1.5. QUICK OVERVIEW OF CONTENTS.....	1-2
2. OPERATION.....	2-1
2.1. SYSTEM POWER-UP.....	2-1
2.2. ANTENNA INITIALIZATION	2-1
2.3. ANTENNA STABILIZATION	2-1
2.4. STABILIZED PEDESTAL ASSEMBLY OPERATION.....	2-1
2.5. TRACKING OPERATION.....	2-2
2.6. ANTENNA POLARIZATION OPERATION.....	2-2
2.7. LOW NOISE BLOCK CONVERTER OPERATION	2-2
2.8. RF EQUIPMENT.....	2-2
2.9. FCC TX MUTE FUNCTION.....	2-2
2.10. RADOME ASSEMBLY OPERATION.....	2-2
3. BASIC SYSTEM INFORMATION.....	3-1
3.1. SATELLITE BASICS.....	3-1
3.1.1. <i>Ku-Band Frequency (10.95-12.75GHz)</i>	3-1
3.1.2. <i>Signal level</i>	3-2
3.1.3. <i>Satellite Footprints</i>	3-2
3.1.4. <i>Satellite polarization</i>	3-2
3.2. ANTENNA BASICS.....	3-3
3.2.1. <i>Unlimited Azimuth</i>	3-3
3.2.2. <i>Elevation</i>	3-3
3.2.3. <i>Antenna Reflector/Feed Assembly</i>	3-3
3.2.4. <i>Antenna polarization</i>	3-3
3.2.5. <i>Fixed frequency or Dual-band LNBS</i>	3-4
3.2.6. <i>Stabilization</i>	3-4
3.2.7. <i>Search Pattern</i>	3-4
3.2.8. <i>Tracking Receiver - Satellite Identification Receiver</i>	3-4
3.2.9. <i>Tracking</i>	3-4
3.3. COMPONENTS OF THE SYSTEM CONFIGURATION	3-5
3.3.1. <i>Antenna ADE Assembly</i>	3-5
3.3.2. <i>Antenna Control Unit</i>	3-5
3.3.3. <i>Above Decks AC Power Supply</i>	3-6
4. INSTALLATION	4-1
4.1. UNPACKING AND INSPECTION	4-1
4.2. SITE SELECTION ABOARD SHIP.....	4-1
4.3. ASSEMBLY NOTES AND WARNINGS.....	4-1
4.4. INSTALLING THE ABOVE-DECKS EQUIPMENT (ADE)	4-2

4.4.1. 50" Radome Assembly 4-2

4.4.2. Antenna Pedestal Mechanical Checks 4-2

4.5. CABLE INSTALLATION 4-3

4.5.1. Shipboard Cable Installation 4-3

4.5.2. Switching Cross-Pol/Co-Pol Receive Output from the Antenna: 4-3

4.6. BELOW DECKS EQUIPMENT. 4-4

4.6.1. System Configuration 4-4

4.6.2. Installing the Below Deck Equipment 4-4

4.6.3. Antenna Control Unit Connections 4-5

4.6.4. Terminal Mounting Strip Connections 4-5

4.6.5. Control Cable Connections 4-5

4.6.6. NMEA GPS, Modem Lock & TX Inhibit Output Cable Connections 4-5

4.6.7. Ships Gyro Compass Connections 4-5

4.6.8. IF Cable Connections 4-5

4.6.9. AGC Tracking Input Connections 4-5

4.7. BROADBAND CONNECTIONS BELOW DECKS 4-5

4.8. SET-UP & CONFIGURATION 4-5

5. SET-UP & CONFIGURATION 5-1

5.1. OPERATOR SETTINGS 5-1

5.2. OPTIMIZING TARGETING 5-1

5.3. OPTIMIZING AUTO-POLARIZATION TX/RX 5-1

5.4. CALIBRATING RELATIVE ANTENNA POSITION (HOME FLAG OFFSET) 5-2

5.4.1. To Calculate HFO: 5-3

5.4.2. To Enter the HFO value: 5-4

5.5. RADIATION HAZARD AND BLOCKAGE MAPPING (AZ LIMIT PARAMETERS) 5-5

5.6. TX POLARITY SETUP 5-8

5.7. DEFAULT SETUP PARAMETERS 5-9

6. FUNCTIONAL TESTING 6-1

6.1. ACU / ANTENNA SYSTEM CHECK 6-1

6.2. LATITUDE/LONGITUDE AUTO-UPDATE CHECK 6-1

6.3. SHIP HEADING – GYRO COMPASS FOLLOWING CHECK 6-1

6.4. AZIMUTH & ELEVATION DRIVE 6-1

6.5. FOUR QUADRANT TRACKING TEST 6-2

6.6. BLOCKAGE SIMULATION TEST 6-2

6.7. TEST BROADBAND OPERATION 6-3

6.8. TEST VOICE OVER IP (VOIP) OPERATION 6-3

7. MAINTENANCE AND TROUBLESHOOTING 7-1

7.1. WARRANTY INFORMATION 7-1

7.2. RECOMMENDED PREVENTIVE MAINTENANCE 7-2

7.2.1. Check ACU Parameters 7-2

7.2.2. Latitude/Longitude Auto-Update check 7-2

7.2.3. Heading Following 7-2

7.2.4.	<i>Azimuth & Elevation Drive</i>	7-2
7.2.5.	<i>Test Tracking</i>	7-2
7.2.6.	<i>Visual Inspection - Radome & Pedestal</i>	7-2
7.2.7.	<i>Mechanical Checks</i>	7-2
7.2.8.	<i>Check Balance</i>	7-3
7.2.9.	<i>Observe Antenna Initialization</i>	7-3
7.3.	TROUBLESHOOTING.....	7-3
7.3.1.	<i>Theory Of Stabilization Operation</i>	7-3
7.3.2.	<i>Series 06 TXRX Antenna Initialization</i>	7-4
7.3.3.	<i>Antenna Position Error Monitoring</i>	7-4
7.3.4.	<i>Reference Sensor Testing</i>	7-5
7.3.5.	<i>Open Loop Rate Sensor Test</i>	7-5
7.3.6.	<i>Open Loop Motor Test</i>	7-5
7.3.7.	<i>To Disable/Enable DishScan</i>	7-6
7.3.8.	<i>Satellite Reference Mode</i>	7-6
7.3.9.	<i>To Read/Decode an ACU Error Code 0008 (Pedestal Error):</i>	7-6
7.3.10.	<i>Get Remote GPS LAT/LON Position:</i>	7-8
7.4.	MAINTENANCE.....	7-8
7.4.1.	<i>Balancing the Antenna</i>	7-8
7.4.2.	<i>24 VDC Polang Alignment</i>	7-8
7.4.3.	<i>To Adjust Tilt:</i>	7-9
7.4.4.	<i>To Reset/Reinitialize the Antenna:</i>	7-9
7.4.5.	<i>Switching Cross-Pol/Co-Pol Receive Output from the Antenna:</i>	7-10
7.5.	PEDESTAL CONTROL UNIT CONFIGURATION – SERIES 06	7-11
7.5.1.	<i>To configure the PCU:</i>	7-11
7.5.2.	<i>Model Configuration Numbers</i>	7-11
7.6.	ANTENNA STOWING PROCEDURE.....	7-12
8.	4006-33 TECHNICAL SPECIFICATIONS	8-1
8.1.	ANTENNA REFLECTOR/FEED 4006	8-1
8.2.	TX RADIO PACKAGE	8-1
8.3.	PEDESTAL CONTROL UNIT.....	8-1
8.4.	UNLIMITED AZIMUTH MODEM/MULTIPLEXER (3 CHANNEL)	8-2
8.5.	STABILIZED ANTENNA PEDESTAL ASSEMBLY	8-3
8.6.	RADOME ASSEMBLY, 50"	8-4
8.7.	ADE PEDESTAL POWER REQUIREMENTS:.....	8-4
8.8.	ENVIRONMENTAL CONDITIONS (ABOVE DECKS EQUIPMENT).....	8-4
8.9.	BELOW DECKS EQUIPMENT	8-5
8.9.1.	<i>DAC-2202 Antenna Control Unit (ACU)</i>	8-5
8.9.2.	<i>Terminal Mounting Strip (TMS)</i>	8-5
8.9.3.	<i>Satellite Modem</i>	8-5
8.9.4.	<i>Router</i>	8-5
8.10.	CABLES.....	8-5

8.10.1. *Antenna Control Cable (Provided from ACU-MUX)* 8-5

8.10.2. *Antenna L-Band IF Coax Cables (Customer Furnished)*..... 8-5

8.10.3. *Multi-conductor Cables (Customer Furnished)* 8-6

8.10.4. *AC Power Cable Above Decks (Customer Furnished)*..... 8-6

8.10.5. *Gyro Compass Interface Cable (Customer Furnished)* 8-6

9. DRAWINGS..... **9-1**

9.1. 4006-33 KU-BAND MODEL SPECIFIC DRAWINGS 9-1

9.2. 4006 GENERAL DRAWINGS..... 9-1

1. Introduction



WARNING: *RF Radiation Hazard - This stabilized antenna system is designed to be used with transmit/receive equipment manufactured by others. Refer to the documentation supplied by the manufacturer which will describe potential hazards, including exposure to RF radiation, associated with the improper use of the transmit/receive equipment. Note that the transmit/receive equipment will operate independently of the stabilized antenna system.*

The ultimate responsibility for safety rests with the facility operator and the individuals who work on the system.

1.1. General System Description

Your system includes a fully stabilized antenna that has been designed and manufactured so as to be inherently reliable, easy to maintain, and simple to operate. The equipment essentially permits unattended operation except for start-ups or when changing to different transponders, or satellites.

1.2. Purpose

This shipboard Transmit-Receive (TXRX) system provides you with two-way satellite voice/data broadband communications while underway on an ocean-going vessel. This can be used to provide a wide variety of telephone, fax and high speed data applications. Your antenna system can transmit to and receive from any desired Ku-band satellite which has adequate signal coverage in your current geographic area. This input will be distributed to your satellite modem and then to all of your other below decks computer, fax and telephone equipment.

1.3. System Components

The 4006 TXRX system consists of two major groups of equipment; an above-decks group and a below-decks group. Each group is comprised of, but is not limited to, the items listed below. All equipment comprising the Above Decks is incorporated inside the radome assembly and is integrated into a single operational entity. For inputs, this system requires only an unobstructed line-of-sight view to the satellite, Gyro Compass input and AC electrical power.

For more information about these components, refer to the Basic System Information section of this manual.

A. Above-Decks Equipment (ADE) Group

1. Stabilized antenna pedestal
2. Antenna Reflector
3. Feed Assembly with LNB(s)
4. Ku-Band Solid State Block Up-Converter (SSPBUC)
5. Radome Assembly

B. Below-Decks Equipment Group

6. Antenna Control Unit
7. Splitter with desired number of outputs (one output to the ACU and one output to the Satellite Modem are required).
8. Satellite Modem and other below decks equipment required for the desired communications purposes.

- 9. Other below decks LAN and VOIP equipment
- 10. Ethernet and telephone cables

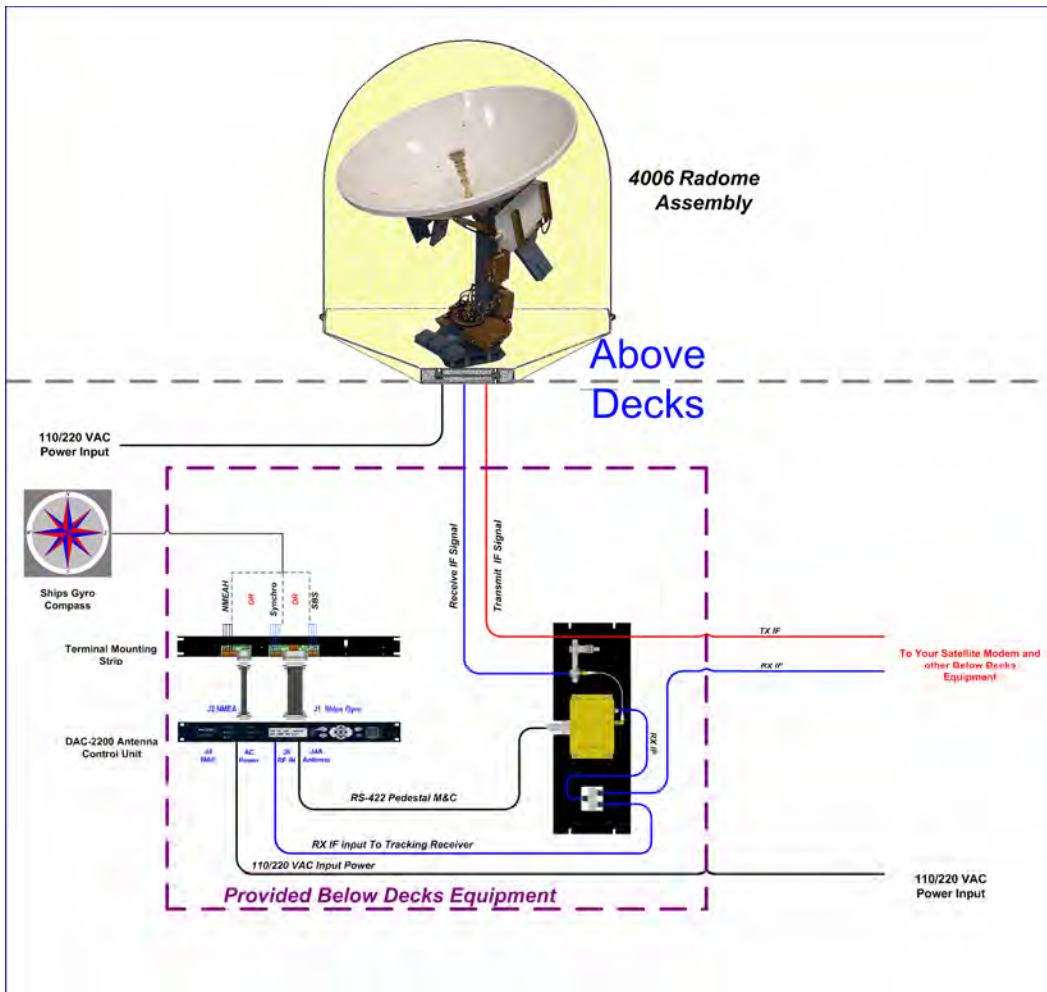

Figure 1-1 4006 Simplified Block Diagram

1.4. General scope of this manual

This manual describes the Sea Tel Series 03 Antenna (also called the Above Decks Equipment), its' operation and installation. Refer to the manual provided with your Antenna Control Unit for its' installation and operating instructions.

1.5. Quick Overview of contents

The information in this manual is organized into chapters. Operation, basic system information, installation, setup, functional testing, maintenance, specifications and drawings relating to this Antenna are all contained in this manual

2. Operation

Operation of your system is accomplished from the DAC-2200 Antenna Control Unit (ACU). Refer to the operation section of the DAC-2200 Antenna Control Unit manual.

2.1. System Power-up

Turn the Power switch on rear panel of the Antenna Control Unit (ACU) ON.

2.2. Antenna Initialization

A functional operation check can be made on the antenna stabilization system by observing its behavior during the 4 phases of initialization.

Turn the pedestal power supply ON. The PCU will initialize the stabilized portion of the mass to be level with the horizon and at a prescribed Azimuth and Elevation angles. The antenna will go through the specific sequence of steps (listed below) to initialize the antenna. These phases initialize the level cage, elevation, cross-level and azimuth to predetermined starting positions.

Initialization is completed in the following phases, each phase must complete properly for the antenna to operate properly (post-initialization).

1. Level Cage is driven CCW, issuing extra steps to assure that the cage is all the way to the mechanical stop. Then the Level cage will be driven exactly 45.0 degrees CW.
2. Elevation axis activates - Input from the LV axis of the tilt sensor is used to drive the Elevation of the equipment frame to bring the tilt sensor LV axis to level (this results in the dish being at an elevation angle of 45.0 degrees).
3. Cross-Level axis activates - Input from the CL axis of the tilt sensor is used to drive Cross-Level of the equipment frame to bring the cross-level axis of the tilt sensor to level (this results in the tilt of the Cross-Level Beam being level).
4. Azimuth axis activates - Antenna drives in azimuth until the "Home Flag" signal is produced. This signal is produced by a Hall Effect sensor coming into close proximity to a Magnet mounted in the azimuth driven sprocket.

This completes the phases of initialization. At this time the antenna elevation should 45.0 degrees and Relative azimuth should be at be at home flag (magnet in the azimuth driven sprocket is at the hall sensor mounted in the PCU enclosure).

If any of these steps fail, or the Antenna Control Unit reports model number as "xx03" or "xx06" re-configure the PCU as described in section the Maintenance section of this manual. If initialization still fails, refer to the troubleshooting section of this manual.

2.3. Antenna Stabilization

After initialization has completed, real-time stabilization of the antenna is an automatic function of the PCU.

2.4. Stabilized Pedestal Assembly Operation

Operation of the stabilized antenna Pedestal Control Unit (PCU) is accomplished remotely by the Antenna Control Unit (ACU). Refer to the Operation section of the Antenna Control Unit manual for more specific operation details. There are no other operating instructions applicable to the pedestal assembly by itself.

2.5. Tracking Operation

Tracking optimizes the antenna pointing, in very fine step increments, to maximize the level of the satellite signal being received. The mode of tracking used in this antenna is a variation of Conical Scanning called DishScan. Tracking is controlled by the ACU. You can toggle Tracking ON/OFF from the ACU.

DishScan continuously drives the antenna in a very small circular pattern at 60 RPM. The ACU evaluates the received signal throughout each rotation to determine where the strongest signal level is (Up, Right, Down or Left) and then issues the appropriate Azimuth and/or Elevation steps to move the antenna toward where stronger signal is.

The pedestal cannot control tracking. Refer to the ACU manual for more Tracking information.

2.6. Antenna Polarization Operation

Linear feeds are equipped with a polarization motor and potentiometer feedback and are controlled from the Antenna Control Unit. Circular feeds do NOT require polarization adjustment.

Auto-Polarization mode is the default polarization mode of operation from the ACU. Polarization may be operated manually from the ACU. Refer to the Antenna Control Unit manual for more operation information.

2.7. Low Noise Block Converter Operation

There are no operating instructions or controls applicable to the LNBS. The ACU provides DC power to the desired LNB via the coax rotary joint and the pedestal modem.

A Cross-Pol LNB is installed on the receive port of the feed assembly and its' output coax is routed to the pedestal modem (labeled "Cross-Pol"). A diplexer is installed in the TX waveguide between the BUC and the TX port of the feed assembly. A Co-Pol LNB is installed on the RX output of the diplexer and its' output coax is routed to the pedestal modem (labeled "Co-Pol"). The desired output to be sent below decks (Co-Pol or Cross-Pol) is selected by connecting the correct coax to the pedestal modem.

2.8. RF Equipment

The RF Equipment is not operated or controlled by the antenna pedestal or Antenna Control Unit. Refer to the vendor supplied manuals for the RF Equipment provided with your system.

2.9. FCC TX Mute Function

FCC TX Mute function provides a transmit inhibit, or mute, signal to the Satellite Modem to disable transmit whenever the antenna is blocked, searching, targeting or is mispointed 0.5 degrees from peak satellite position. This function is provided by software in the ACU & PCU, hardware wiring connection between the ACU and the Satellite Modem and proper setup of the ACU SYSTEM TYPE parameter.

After the function has been installed and setup correctly the FCC TX Mute function operation is automatic, therefore, requires no operator intervention. Refer to the Installation and Setup chapters in this manual and in your Antenna Control Unit manual.

2.10. Radome Assembly Operation

When operating the system it is necessary that the radome access hatch (and/or side door) be closed and secured in place at all times. This prevents rain, salt water and wind from entering the radome. Water and excessive condensation promote rust & corrosion of the antenna pedestal. Wind gusts will disturb the antenna pointing.

There are no other operating instructions applicable to the radome assembly by itself.

3. Basic System Information

This section provides you with some additional information about the satellites you will be using, basics of the your antenna system and other equipment within your system configuration.

3.1. Satellite Basics

The satellites are in orbit at an altitude of 22,753.2 Statute Miles positioned directly above the equator. Their orbital velocity matches the Earth's rotational speed, therefore, each appears to remain at a fixed position in the sky (as viewed from your location).

The satellites are simply relay stations that are able to receive signals from one location on the globe and re-transmit them to a much larger area on the globe than a local antenna could do. Because of their high vantage point, they are able to cover an area that is larger than a continent.

Your antenna can be used with any of the Ku-Band (10.95-12.75GHz) satellites in this orbit that have a strong enough receive signal level in your location. Your antenna is capable of transmitting and receiving Linear signal polarization, but requires that you have the appropriate LNB installed for the specific frequency range of that satellite.

If you could see the satellites in their positions above the equator, they would appear to form an arc as shown here (as viewed from a position in the Northern Hemisphere). When you are on the same longitude as the satellite, its' horizontal and vertical signals will be purely aligned to your horizon. When the satellite is east or west of your longitude, the satellite signals will appear to be rotated clockwise or counter-clockwise from pure horizontal and vertical. Both horizontal and vertical signals from a satellite will appear to be rotated the same amount and are always perpendicular to each other. The amount of rotation is dependent on how far east or west the satellite is from you and how close you are to the Equator.

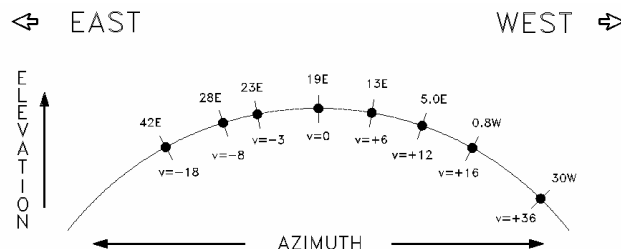

Figure 3-1 Arc of viewable Satellites

3.1.1. Ku-Band Frequency (10.95-12.75GHz)

At these frequencies the signal from the satellite travels only in a straight line and is affected by weather changes in the atmosphere. There are several conditions that can cause a temporary loss of satellite signal, even within an area where the signal level is known to be adequate. The most common of these *normal* temporary losses are **blockage** and **rain fade**. They will normally interrupt services only as long as the cause of the loss persists.

Blockage - Blockage is loss due to an object in the path of the signal from the satellite to the dish. If an object that is large and dense is positioned in the path of the signal from the satellite, it will prevent sufficient signal from arriving at the dish. The signal can not bend around, or penetrate through, these objects. The reception will be degraded or completely interrupted until the object is no longer in the path of the signal to the dish. The dish is actively driven to remain pointed at the satellite (toward the equator) so, as the boat turns a mast or raised structure on the boat may become positioned between the satellite and the dish. Blockage may also be caused a person standing near the radome, tall mountains, buildings, bridges, cranes or other larger ships near your boat. Signal will be lost when the boat is housed inside an enclosure that the signal cannot penetrate, like a paint shed or a berth with a roof. Moving or rotating the boat

to position the antenna where it has an unobstructed view to the desired satellite will restore the antennas ability to receive the satellite signal.

Rain Fade - Atmospheric conditions that may cause sufficient loss of signal level include rain, snow, heavy fog and some solar activities such as sun spots and solar flare activity. The most common of these is referred to as "rain fade". Rain drops in the atmosphere reduce the signal from the satellite. The heavier the rain, the greater the signal loss. When the amount of loss is high enough, the antenna will not be able to stay locked onto the satellite signal. Once the amount of rain has decreased sufficiently, the antenna will re-acquire the satellite signal. In strong signal areas, rain fall of about four inches per hour will cause complete loss of signal. In weaker signal areas, lighter rainfall might cause the signal to be lost.

3.1.2. Signal level

The level of the receive signal on a point on the globe is dependant upon how powerful the transmission is and how wide the signal beam is coverage area is. Focusing the signal into a narrower beam concentrates its energy over a smaller geographic area, thereby increasing the signal level throughout that area of coverage. This makes it possible for you to use a smaller antenna size to receive that satellite signal. The antenna system must be geographically located in an area where the signal level from the satellite meets (or exceeds) the minimum satellite signal level required for your size of antenna (refer to the Specifications section of this manual) to provide suitable reception. This limits the number of satellites that can be used and the geographic areas where the ship can travel where the signal level is expected to be strong enough to continue providing uninterrupted reception. When travelling outside this minimum signal coverage area, it is normal for the system to experience an interruption in its ability to provide the desired satellite services until entering (or re-entering) an area of adequate signal level (refer to the satellite footprint information). Systems with larger diameter dish antennas can receive signal further out towards the fringe of a given satellites coverage area.

3.1.3. Satellite Footprints

The focused beam(s) from the satellites are normally aimed at the major land masses where there are large population centers. Footprint charts graphically display the signal level expected to be received in different geographic locations within the area of coverage. The signal will always be strongest in the center of the coverage area and weaker out toward the outer edges of the pattern. The Drawing section of this manual contains footprint charts of satellites that are expected to provide adequate signal level for your size antenna. The coverage areas are intended to be a guide to reception, however, the actual coverage area and signal level and vary. Also the signal strength is affected by weather.

3.1.4. Satellite polarization

The satellites you will be using transmit their signals in linear polarization mode (like a flat ribbon down from the satellite).

The feed assembly installed on your antenna is designed to be fitted with a linear LNB (to receive horizontal and vertical linear polarized satellite transmissions. A motor, which is controlled by the ACU (Auto or Manual polarization), adjusts the "polarization" angle of the LNB installed on the feed to optimize the alignment of the LNB to match the angle of the signal from the satellite. Auto-Polarization mode of the ACU normally will keep the polarization optimized for you. When you are on the same longitude as the satellite, its' horizontal and vertical signals will be purely aligned to your horizon. When the satellite is east or west of your longitude, the satellite signals will appear to be rotated clockwise or counter-clockwise from pure horizontal and vertical. Both horizontal and vertical signals from a satellite will appear to be rotated the same amount and are always perpendicular to each other. The amount of rotation is dependent on how far east or west the satellite is from you and how close you are to the Equator.

3.2. Antenna Basics

The satellite dish is mounted on a three jointed pedestal. As your boat rolls, pitches and turns in the water, these three joints move to keep the dish pointed at the satellite. The following information is provided to explain some of the basic functions of the antenna:

3.2.1. Unlimited Azimuth

Azimuth rotation of the antenna is unlimited (no mechanical stops). Azimuth drive, provided by the azimuth motor, is required during stabilization, searching and tracking operations of the antenna. When the ship turns, azimuth is driven in the opposite direction to remain pointed at the satellite. The actual azimuth pointing angle to the satellite is determined by your latitude & longitude and the longitude of the satellite. It is important to know that the antenna should be pointed (generally) toward the equator.

The azimuth angle to the satellite would be 180 degrees true (relative to true north) if the satellite is on the same longitude that you are on. If the satellite is east, or west, of your longitude the azimuth will be less than, or greater than 180 degrees respectively.

When checking for blockage you can visually look over the antenna radome toward the equator to see if any objects are in that sighted area. If you are not able to find any satellites it may also be useful to remove the radome hatch to visually see if the dish is aimed the correct direction (towards the equator).

3.2.2. Elevation

The antenna can physically be rotated in elevation from -15 degrees (lower stop) to +120 degrees (upper stop). However, you will only be pointing elevation between 00.0 (horizon) and 90.0 (zenith). Elevation drive, provided by the elevation motor, is required during stabilization, searching and tracking operations of the antenna. The actual elevation pointing angle to the satellite is determined by your latitude & longitude and the longitude of the satellite. In general terms, the elevation angle will be low when the ship is at a high latitude and will increase as the ship gets closer to the equator.

Additionally, from any given latitude, the elevation will be highest when the desired satellite is at the same longitude that you are on (refer to figure 3-1). If the desired satellite is east, or west, of your longitude the elevation angle will be lower.

3.2.3. Antenna Reflector/Feed Assembly

Comprised of a aluminum reflector with a Cassegrain feed assembly. The feed assembly is fitted with a polarization motor and a potentiometer for position feedback required for linear signal operation. A variety of interchangeable LNBS can be easily fitted to the feed, allowing it to be fitted with the appropriate frequency range LNB for the desired Ku-Band satellite.

The ACU automatically adjusts the polarization of the feed by remotely controlling the 24 volt DC motor, using the potentiometer feedback for Linear polarization position (Auto-Polarization mode).

3.2.4. Antenna polarization

When you have a linear LNB installed the polarization needs to be periodically adjusted, Auto-Polarization will automatically accomplish this for you.

To adjust polarization UP the LNB (as viewed from the front side of the reflector) must rotate CCW and to adjust polarity DOWN the LNB must rotate CW.

Polarization adjustment to optimize Auto-Pol is required when initially setting up the system or after you have installed a different LNB (refer to the Maintenance Section of this manual).

3.2.5. Fixed frequency or Dual-band LNBS

Your antenna can easily be fitted with a variety of LNBS. The LNB must match the frequency band of the desired satellite. The Dual Band LNB is able to be electrically switched from low band to high band from the antenna control unit. You must also have the correct option file loaded into your satellite modem for the LNB you have installed, or the band you currently have selected, to be able to use a specific satellite and its' voice & data services.

3.2.6. Stabilization

This Sea Tel antenna is stabilized in three axes of motion. Stabilization is the process of decoupling the ships motion from the antenna. Simply put, this allows the antenna to remain pointed at the satellite while the boat turns, rolls or pitches under it. To accomplish this, the Pedestal Control Unit (PCU) on the antenna pedestal senses any motion of the antenna and immediately applies drive to the appropriate motor(s) to oppose the sensed motion. Azimuth (AZ), Elevation (EL) and Cross-Level (left-right tilt) are actively stabilized automatically by the PCU as part of its normal operation.

3.2.7. Search Pattern

Whenever the desired satellite signal is lost (such as when the antenna is blocked), the Antenna Control Unit will automatically initiate a search to re-acquire the desired signal.

The search is conducted with alternate azimuth and elevation movements. The size and direction of the movements are increased and reversed every other time resulting in an expanding square pattern.

When the antenna finds the desired satellite signal, the ACU will automatically stop searching and begin Tracking the signal. Tracking optimizes the pointing of the antenna to get the highest signal level from the satellite.

3.2.8. Tracking Receiver - Satellite Identification Receiver

The Satellite Identification Receiver located in the Antenna Control Unit (ACU) is used to acquire, identify and track a specific satellite by a unique network ID code (NID). Some TVRO signals may not allow the NID to be demodulated. In these cases, the ACU may be programmed to generate its own "ID" based on a pattern match comprised of frequency, baud rate and FEC rate. In addition, an external modem lock input to the ACU is used as a satellite ID when the appropriate SYSTEM TYPE value is used.

The receiver must be set up properly for the satellite you wish to find & track. These receiver settings should be saved to expedite finding, or re-acquiring, the desired satellite in the future.

When searching for a desired satellite, this receiver compares any satellite ID it finds to the saved satellite ID code. If the ID code does not match the antenna will continue searching until the correct satellite is found. The system must have adequate satellite signal level, AND the matching ID, to stop searching (and continue tracking the desired satellite). Refer to your ACU manual for more information.

3.2.9. Tracking

The ACU actively optimizes the pointing of the dish for maximum signal reception. This process is called tracking and is accomplished by continuously making small movements of the dish while monitoring the level of the received signal. Evaluation of this information is used to continuously make minor pointing corrections to keep the signal level "peaked" as part of normal operation.

3.3. Components of the System Configuration

The following text provides a basic functional overview of the system components and component interconnection as referred to in the simplified block diagram below. Also, refer to the appropriate page of the System Block Diagram which depicts your system configuration for further detail.

The System is comprised of two major sections: The Above-Decks Equipment (ADE) is comprised solely of the antenna radome assembly which is mounted outside, on the boats upper deck or mast location. The Below-Decks Equipment (BDE) includes the Antenna Control Unit, satellite modem and all other ancillary equipment that is mounted in various locations throughout the interior of the boat.

3.3.1. Antenna ADE Assembly

The Above Decks Equipment consists of an Antenna Pedestal inside a Radome assembly. The pedestal consists of a satellite antenna dish & feed with a linear Low Noise Block converter (LNB) with polarization motor mounted on a stabilized antenna pedestal.

The radome provides an environmental enclosure for the antenna pedestal assembly inside it. This keeps wind, water condensation and salt-water spray off the antenna pedestal assembly. This prevents damage and corrosion that would shorten the expected life span of the equipment.

RG-11 (or better) coax cables are connected from the antenna radome assembly to the below decks equipment. The two cables carry the intermediate frequency (950-2050MHz) signals from the antenna assembly directly to the below decks equipment. Antenna control communication between the Antenna Control Unit and the Pedestal Control Unit are also on one of these coax cables.

And finally an AC Power cable is also routed to the antenna to provide the operating voltage to the antenna assembly



Figure 3-2 4006 Above Decks Equipment

3.3.2. Antenna Control Unit

The Antenna Control Unit allows the operator to control and monitor the antenna pedestal with dedicated function buttons, LED's and a 2 line display. The ACU and its Terminal Mounting Strip are normally mounted in a standard 19" equipment rack. The ACU should be mounted in the front of the equipment rack where it is easily accessible. The Terminal Mounting Strip is normally mounted on the rear of the equipment rack. It is recommended that the antenna control panel be mounted near one of the Satellite Receiver locations where you can see the television screen while you are controlling the antenna.

The Antenna Control Unit is connected to the antenna, ships Gyro Compass and modem.

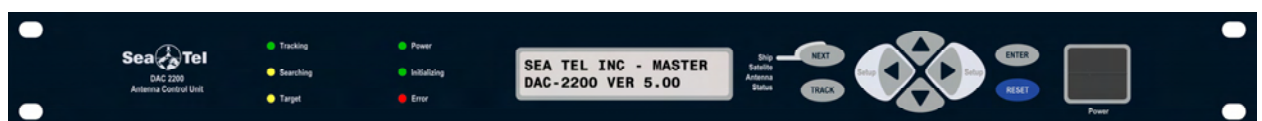

Figure 3-3 Antenna Control Unit

The Antenna Control Unit (ACU) communicates via an RS-422 full duplex data link with the Pedestal Control Unit (PCU) located on the antenna. This control signal to/from the antenna is on the Coax cable along with the DC voltage which energizes the LNB and the L-Band Receive IF from the LNB. The Pedestal Control Unit stabilizes the antenna against the ship's roll, pitch, and turning motions. The ACU is the operator interface to the PCU and provides the user with a choice of positioning commands to point the antenna, search commands to find the satellite signal and tracking functions to maintain optimum pointing.

3.3.3. Above Decks AC Power Supply

Pedestal Power - An appropriate source of AC Voltage (110 VAC 60 Hz OR 220 VAC 50 Hz) is required for the above decks equipment. Total power consumption will depend on the number of equipments connected to this power source.

RF Equipment (TX/RX Systems ONLY) - The AC voltage source should be well regulated and surge protected. Uninterrupted Power Supplies are frequently installed (below decks) to provide power for the antenna pedestal, especially if RF Equipment is installed on the pedestal. Refer to the Specifications section of this manual for the power consumption of the antenna pedestal and RF Equipment.

Marine Air Conditioner Unit (TX/RX Systems ONLY) - If a marine air conditioner is included with your system, the AC voltage source should be from a separate AC Power breaker source than the antenna pedestal. AC power for the air conditioner should be well regulated and surge protected, but does NOT need to from an Uninterrupted Power Supply. Refer to the marine air conditioner manual for its' power requirements and consumption specifications.

4. Installation

Your antenna pedestal comes completely assembled in its radome. This section contains instructions for unpacking, final assembly and installation of the equipment. It is highly recommended that installation of the system be performed by trained technicians.

4.1. Unpacking and Inspection

Exercise caution when unpacking the equipment. Carefully inspect the radome surface for evidence of shipping damage.

4.2. Site Selection Aboard Ship

The radome assembly should be installed at a location aboard ship where:

- The antenna has a clear line-of-sight to as much of the sky (horizon to zenith at all bearings) as is practical.
- The antenna is a minimum of 15 Feet from the ship's Radar, further away if they are high power Radar arrays.
- The antenna is not mounted on the same plane as the ship's Radar, so that it is not directly in the Radar beam path.
- The antenna is a minimum of 15 Feet from high power short wave transmitting antennas.
- The Above Decks Equipment (ADE) and the Below Decks Equipment (BDE) should be positioned as close to one another as possible. This is necessary to reduce the losses associated with long cable runs.
- The mounting location is rigid enough that it will not flex, or sway, in ships motion or vibration. If the radome is to be mounted on a raised pedestal, it **MUST** have adequate gussets, or be well guyed, to prevent flexing or swaying in ships motion.

If these conditions cannot be entirely satisfied, the site selection will inevitably be a "best" compromise between the various considerations.

4.3. Assembly Notes and Warnings





NOTE: Unless otherwise indicated, all nuts and bolts should be assembled with Loctite 271 or its equivalent.

	WARNING: Assure that all nut & bolt assemblies are tightened according the tightening torque values listed below:	
	Bolt Size	Inch Pounds
	1/4-20	75
	5/16-18	132
	3/8-16	236
	1/2-13	517

4.4. **Installing the Above-Decks Equipment (ADE)**

4.4.1. **50" Radome Assembly**

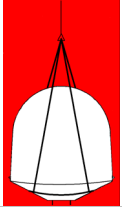
The antenna pedestal is shipped completely assembled in its 48" radome.

	<p>WARNING: Hoisting with other than a webbed four-part sling may result in catastrophic crushing of the radome. Refer to the specifications and drawings for the fully assembled weight of your model Antenna/Radome and assure that equipment used to lift/hoist this system is rated accordingly.</p>
	<p>CAUTION: The antenna/radome assembly is very light for its size and is subject to large swaying motions if hoisted under windy conditions. Always ensure that tag lines, attached to the radome base frame, are attended while the antenna assembly is being hoisted to its assigned location aboard ship.</p>

1. Remove the shipping nuts which mount the ADE to its' pallet.
2. Using a web strap lifting sling arrangement, and with a tag line attached near the radome base, hoist the antenna assembly to its assigned location aboard ship by means of a suitably sized crane or derrick.
3. The radome assembly should be positioned with the BOW marker aligned as close as possible to the centerline of the ship. Any variation from actual alignment can be compensated with the AZIMUTH TRIM adjustment in the Antenna Control Unit so precise alignment is not required.
4. Bolt the radome base directly to the ship's deck or mounting plate. When completed the radome base should be as near level as possible.

4.4.2. **Antenna Pedestal Mechanical Checks**

1. Open the radome hatch and enter the radome.
2. Inspect the pedestal assembly and reflector for signs of shipping damage.
3. Remove the web strap shipping restraints from the pedestal. Save these straps to restrain the antenna in the event that the AC power will be turned off while the ship is underway.
4. Cut and discard the large white tie-wraps from the pedestal.
5. Remove the Cross-Level shipping bar.
6. Remove the rubber isolation damper from the split post.
7. Check that the antenna moves freely in azimuth, elevation, and cross level without hitting any area of the interior of the radome.
8. Check that the antenna assembly is balanced front to back, top to bottom and side to side by observing that it remains stationary when positioned in any orientation. Refer to section 3.5 for complete information on balancing the antenna.
9. Check that all pedestal wiring and cabling is properly dressed and clamped in place.
10. See cable terminations section below.

4.5. Cable Installation

4.5.1. Shipboard Cable Installation



CAUTION: Rough handling, tight bending, kinking, crushing and other careless handling of the cables and their connectors can cause severe damage.

The cables must be routed from the above-decks equipment group through the deck and through various ship spaces to the vicinity of the below-decks equipment group. When pulling the cables in place, avoid sharp bends, kinking, and the use of excessive force. After placement, seal the deck penetration gland and tie the cables securely in place.

4.5.2. Switching Cross-Pol/Co-Pol Receive Output from the Antenna:

Your antenna can provide Co-Pol, or Cross-Pol, receive signal to your modem.

A Cross-Pol LNB is installed on the receive port of the feed assembly and its' output coax is routed to the pedestal modem (labeled "Cross-Pol"). A diplexer is installed in the TX waveguide between the BUC and the TX port of the feed assembly. A Co-Pol LNB is installed on the RX output of the diplexer and its' output coax is routed to the pedestal modem (labeled "Co-Pol").

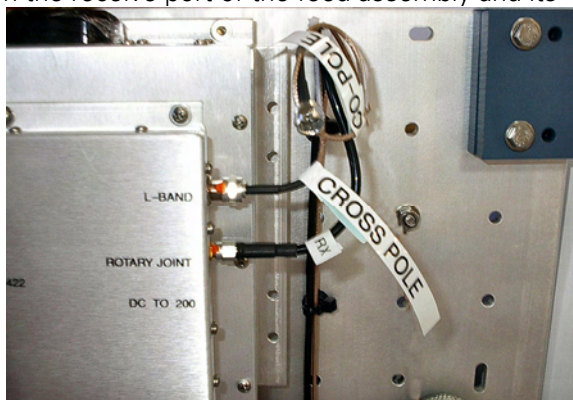

You must select which output you want to be sent to the below decks (Co-Pol or Cross-Pol):

1. Open the radome hatch and set it aside inside the radome.
2. Reach in the hatch opening and turn antenna power OFF (to assure that the antenna is not transmitting when you enter the radome).
3. Climb up so that your upper torso is in the hatch of the radome and rotate the antenna so the dish is at (or near) horizon and is pointed to your right. This will position the right side of the antenna pedestal to be in front of you (as seen in the picture).
4. If Co-Pol receive signal is needed, plug the "Co-Pol" coax into the pedestal modem.
5. If Cross-Pol receive signal is needed, plug the "Cross-Pol" coax into the pedestal modem.
6. Climb down out of the hatch, turn antenna power ON, put the hatch back in place and secure it.

The antenna will reinitialize when you turn the power ON. The ACU provides DC power to the LNB you have plugged into the pedestal modem via the coax rotary joint.

4.6. ***Below Decks Equipment.***

4.6.1. **System Configuration**

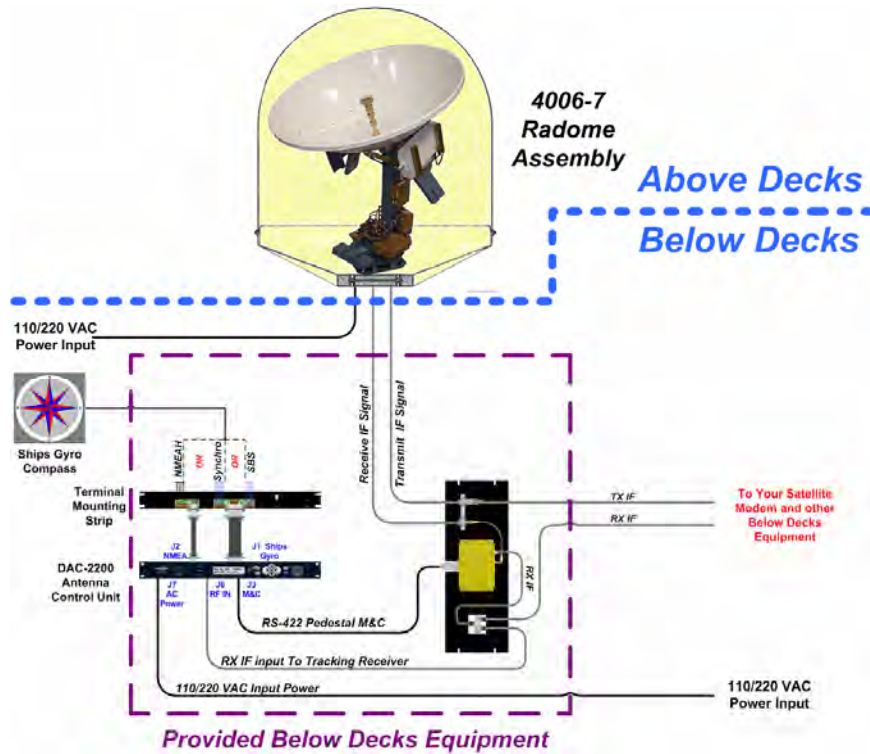

Figure 4-1 4006 Simplified Block Diagram

4.6.2. **Installing the Below Deck Equipment**

<ol style="list-style-type: none"> 1 Install the ACU, Terminal Mounting Strip and Multiplexer Panel in your standard 19" Equipment Rack. 2 Connect this equipment as shown in the System Block Diagram. 3 Install and connect your other Below Decks Equipment (ie, Satellite Modem, telephone and computer equipment). 	
<ol style="list-style-type: none"> 4 Connect the two coaxes from the Radome Assembly to the BDE Rack. <i>The TX Cable should be connected directly to the TX connector on the rear panel of your Satellite Modem.</i> 	
<ol style="list-style-type: none"> 5 Connect Ships Gyro Compass input to the Terminal Mounting Strip on the rear of the BDE Rack. 	
<ol style="list-style-type: none"> 6 Connect the appropriate power cable into the receptacle of the racks power strip. 	

- | | |
|--|--|
| 7 Plug the power cord into a suitable 110, or 220, VAC UPS or AC power outlet. | |
|--|--|

4.6.3. Antenna Control Unit Connections

The DAC-2200 ACU is installed in a BDE Rack and is one rack unit high. It includes a Terminal Mounting Strip mounted on the rear of the rack which is also a one rack unit high plate.

4.6.4. Terminal Mounting Strip Connections

You will connect you Ships Gyro Compass input to the appropriate screw terminals on these strip. (see 4.6.5 below)

4.6.5. Control Cable Connections

The Serial Control Cable is connected from the Base Multiplexer to J1 on the DAC-2200.

4.6.6. NMEA GPS, Modem Lock & TX Inhibit Output Cable Connections

The cable connection from TB 4 on the Terminal Mounting Strip to the Modem is pre-connected at the factory. This connection provides:

- NMEA GPS output (allows the modem to adjust its link timing)
- Modem Lock output from the modem provides a logic input to the ACU to identify when it is on the correct satellite.
- A transmit inhibit output from the ACU will mute the modem transmit when the antenna is mis-pointed 0.5 degrees. This connection is **MANDATORY** to comply with new FCC Order 04-286 and WRC-03 Resolution 902.

4.6.7. Ships Gyro Compass Connections

Connect the cable from the ship's gyro compass repeater to TB1 or TB3 of the Terminal mounting strip. Use TB1 for a Step-By-Step gyro compass and match the connections to COM, A, B and C. Use TB3 for a Synchro gyro compass and match the connections to R1, R2, S1, S2 and S3.

4.6.8. IF Cable Connections

Attach the connectors on the TX and RX IF cables from above decks equipment to the BDE Rack. Attach the TX cable to the Satellite Modem "TX" connection. Attach the RX cable to the Base Multiplexer panel RX connector on the rear of the BDE Rack. RX IF cable from one output of the splitter mounted on the Base Multiplexer panel is connected to the Satellite Modem "RX" connection.

4.6.9. AGC Tracking Input Connections

The other output connection from the splitter mounted on the Base Multiplexer panel is connected to the RF input on the back of the DAC-2200.

4.7. Broadband Connections Below Decks

Refer to System Block Diagram for the Series 03 Ku-Band TX/RX System for connection information.

4.8. Set-up & Configuration

Refer to the next section of this manual for set-up and configuration of the components in this system.

This Page Intentionally Left Blank

5. Set-up & Configuration

The components in the system will have been configured with IP Addresses at the factory. The Front Title Page of this manual has a list of recorded IP address information, serial number information and Modem software version.

In the paragraphs below you will verify the configuration of these components, which will also verify that each of them are communicating. If one of the components has been replaced, it will have to be configured correctly to properly operate as part of this system.

Contact Sea Tel for the Internet Service Provider (ISP) Network Operation Center (NOC) ASSIGNED IP address, SubNet Mask and the Primary & Secondary DNS addresses if they have not been previously provided to you, or if you have changed providers.

5.1. Operator Settings

Refer to the Operation chapter of this manual to set the Ship information. Latitude and Longitude should automatically update when the GPS engine mounted above decks triangulates an accurate location, but you may enter this information manually to begin. If your gyro source is providing Heading information in any format other than NMEA-0183 format, you will have to enter in the initial Ship's Heading position, the Gyro Compass will then keep the ACU updated.

Set the Satellite information, for the satellite you will be using. The receiver settings are especially important. At this point you should be able to target the desired satellite. Continue with the setup steps below to optimize the parameters for your installation.

5.2. Optimizing Targeting

First, assure that all of your Ship & Satellite settings in the ACU are correct. Target the desired satellite, immediately turn Tracking OFF, and record the Azimuth and Elevation positions in the "**ANTENNA**" display of the ACU (these are the **Calculated** positions). Turn Tracking ON, allow the antenna to "Search" for the targeted satellite and assure that it has acquired (and peaks up on) the satellite that you targeted. Allow several minutes for the antenna to "peak" on the signal, and then record the Azimuth and Elevation positions while peaked on satellite (these are the **Peak** positions). Again, assure that it has acquired the satellite that you targeted!

Subtract the Peak Positions from the Calculated Positions to determine the amount of Trim which is required. Refer to the ACU Setup information to key in the required value of Elevation Trim. Continue with Azimuth trim, then re-target the satellite several times to verify that targeting is now driving the antenna to a position that is within +/- 1.0 degrees of where the satellite signal is located.

EXAMPLE: The ACU targets to an Elevation position of 30.0 degrees and an Azimuth position of 180.2 (Calculated), you find that Peak Elevation while ON your desired satellite is 31.5 degrees and Peak Azimuth is 178.0. You would enter an EL TRIM value of -1.5 degrees and an AZ TRIM of +2.2 degrees. After these trims values had been set, your peak **on satellite** Azimuth and Elevation displays would be very near 180.2 and 30.0 respectively.

5.3. Optimizing Auto-Polarization TX/RX

If your system is fitted with a circular feed you do not need to optimize the polarity angle and can skip this procedure. This procedure optimizes the linear polarization of the feed. Verify that tracking is ON and that the antenna is peaked on your targeted satellite (targeting calculates the azimuth, elevation and polarization angles). Assure that you are in Auto-Pol mode (POL TYPE parameter in the ACU is set to 0072) and set your satellite modem (or spectrum analyzer) to view its signal level display. Go to the TX POLARITY parameter in the Setup menu of the ACU and set this parameter to your assigned Transmit polarity (Horizontal or Vertical). Go to the POL OFFSET parameter in the Setup menu of the ACU.

Default setting is 0040 and may be incremented, or decremented, to adjust polarization while in Auto-Pol mode. Each increment equals one degree of polarization rotation (0048 = +8 degrees), decrement below 40 for minus polarization (0032 = -8 degrees). Press the UP arrow to increment or the DOWN arrow to decrement the value and then hit the ENTER key to adjust the feed to the new value. *Allow 30 to 60 seconds between increments or decrements to allow time for feed assembly to drive to new position*

During commissioning, under guidance from the network operation center, you will be adjusting to minimize the effect of your transmission on the opposite polarization which maximizes your Cross-Pol isolation. Contact your satellite provider to help you (over the phone) to optimize the polarity angle for maximum Cross-Pol isolation (this optimizes your transmit polarity and is much more accurate than you trying to optimize your receive polarity). Save your new TX POLARITY and POL OFFSET values (refer to Save New Parameters in your ACU manual).

5.4. Calibrating Relative Antenna Position (Home Flag Offset)

During initialization, azimuth drives the CW antenna until the Home Switch is contacted, which "presets" the relative position counter to the value stored in the Home Flag Offset. This assures that the encoder input increments/decrements from this initialization value so that the encoder does not have to be precision aligned.

The Home Switch is a hall sensor which is actuated by a magnet mounted on the azimuth driven sprocket, which produces the "Home Flag" signal.

The Home Flag Offset is a value saved in NVRam (Non-Volatile RAM) in the PCU. This value is the relative position of the antenna when the home switch is engaged. Presetting the counter to this value assures that when the antenna is pointed in-line with the bow of the ship the counter will read 000.0

Relative (360.0 = 000.0).

In most cases when the antenna stops at the home flag, it will be pointed in-line with the Bow of the ship. In these cases Home Flag Offset (HFO) should be set to zero. When "Optimizing Targeting" small variations (up to +/- 5.0 degrees) in Azimuth can be corrected using If it AZ TRIM as described in the Optimizing Targeting procedure above.

Large variations in Azimuth position indicate that the Relative position is incorrect and should be "calibrated" using the correct HFO value instead of an Azimuth Trim offset. This is especially true if sector blockage mapping is used.

If the antenna stops at the home flag, but it is NOT pointed in-line with the Bow of the ship, it is important to assure that the antennas **actual** position (relative to the bow of the ship) is the value that gets "preset" into the Relative position counter. By saving the antennas **actual** Relative position when at the home flag into HFO, you have calibrated the antenna to the ship.

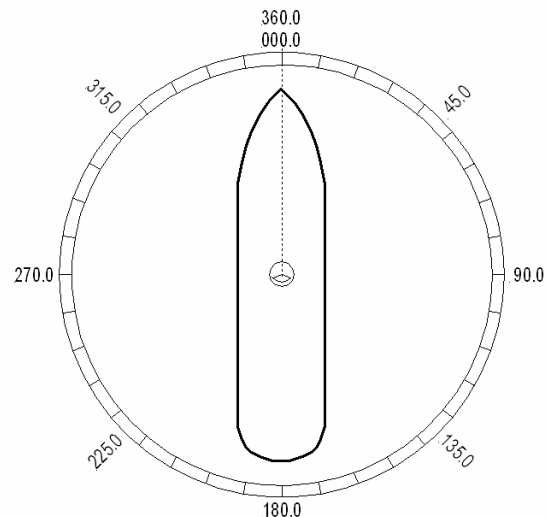

Figure 5-1 Antenna stops In-line with Bow

5.4.1. To Calculate HFO:

If Targeting has been optimized by entering a large value of AZ TRIM; First, verify that you are able to repeatably accurately target a desired satellite (within +/- 1.0 degrees). Then you can use the AZ TRIM value to calculate the value of HFO you should use (so you can set AZ TRIM to zero). AZ Trim is entered as the number of **tenths** of degrees. You will have to convert the AZ TRIM value to the nearest **whole** degree (round up or down as needed). Calculated HFO value is also rounded to the nearest whole number.

If AZ TRIM was a **plus** value: $HFO = (TRIM / 360) \times 255$ Example: AZ TRIM was 0200 (plus 20 degrees). $HFO = (20/360) \times 255 = (0.0556) \times 255 = 14.16$ round off to 14.

If AZ TRIM was a **negative** value: $HFO = ((360-TRIM) / 360) \times 255$ Example: AZ TRIM = -0450 (minus 45 degrees). $HFO = ((360 - 45) / 360) \times 255 = (315 / 360) \times 255 = 0.875 \times 255 = 223.125$ round of to 223.

If Targeting has NOT been optimized, allow the antenna to initialize to its home flag position. Visually compare the antennas pointing to the bow-line of the ship (parallel to the Bow). Note the antennas position relative to the Bow. If it appears to be very close to being parallel to the bow, HFO will probably not be needed and you can proceed with Optimizing Targeting. If it is NOT close [initialization was driving the azimuth CW], note if the antenna appears to have stopped before it got to the Bow or if it went past the Bow. You may be able to guess an approximate amount of how many degrees the antenna is from the bow. This is only intended to help you initially find the satellite (which direction you will have to drive and approximately how far you will have to drive). Refer, in general terms, to the Optimizing Targeting procedure.

If the antenna stopped before it got to the bow-line; When you initially target a satellite, the antenna will also stop prior to the satellite position, so you that will have to drive the Azimuth of the antenna UP to actually find the

satellite. Using the same basic procedure as in the Optimizing Targeting paragraph, target the satellite and record the "Calculated" Azimuth position that the antenna was driven to. Drive UP until you find the satellite, positively identify that you are on **the satellite** you targeted and allow tracking to peak the antenna position. Record the "Peak" Azimuth position. Subtract the "Peak" position from the "Calculated" position to determine the number of degrees of AZ TRIM that would be required.

Example: In this new installation, I target my desired satellite and record the Calculated Azimuth to be 180.5. I drive UP and finally find my desired satellite at a Peak Azimuth of 227.0 degrees. I subtract Peak from Calculated and difference to be -46.5 degrees, therefore the actual Relative position that needs to be preset into the counter when the antenna is at the Home Flag is 313.5. $HFO = ((360-46.5) / 360) \times 255 = (313.5 / 360) \times 255 = 0.87 \times 255 = 222.06$ which I round down to 222.

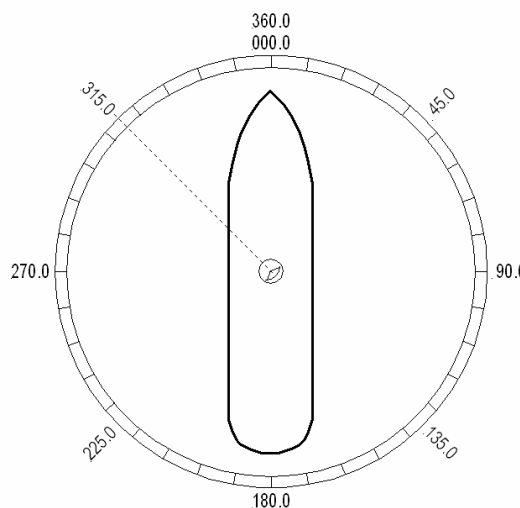

Figure 5-2 Antenna stopped before the Bow

If the antenna went past the bow-line; When you initially target a satellite, the antenna will also go past the satellite position, so that you will have to drive the Azimuth of the antenna DOWN to actually find the satellite. Using the same basic procedure as in the Optimizing Targeting paragraph, target the satellite and record the "Calculated" Azimuth position that the antenna was driven to. Drive DOWN until you find the satellite, positively identify that you are on **the satellite** you targeted and allow tracking to peak the antenna position. Record the "Peak" Azimuth position. Subtract the "Peak" position from the "Calculated" position to determine the number of degrees of AZ TRIM that would be required. Refer to the calculations above to determine the HFO you should use for this antenna.

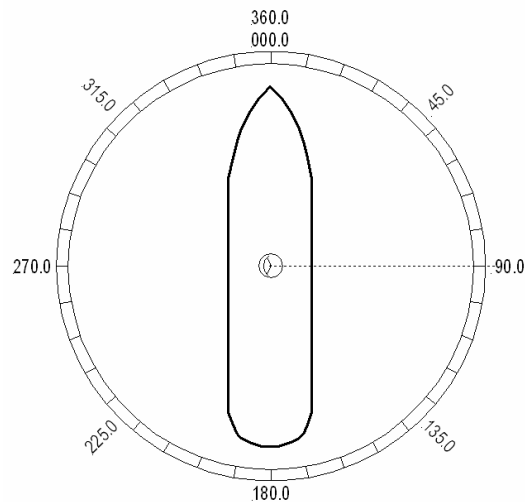

Figure 5-3 Antenna stops past the Bow

Example: In this new installation, I target my desired satellite and record the Calculated Azimuth to be 180.0. I drive DOWN and finally find my desired satellite at a Peak Azimuth of 90.0 degrees. I subtract Peak from Calculated and difference to be +90.0 degrees, therefore the actual Relative position that needs to be preset into the counter when the antenna is at the Home Flag is 90.0. $HFO = ((90.0) / 360) \times 255 = 0.25 \times 255 = 63.75$ which I round up to 64.

5.4.2. To Enter the HFO value:

To enter the calculated HFO value, press & hold both LEFT and RIGHT arrows for six seconds to enter the parameter menu at the EL TRIM parameter window. Press DOWN arrow key numerous times (about 21) until you have selected the REMOTE COMMAND window.

In the REMOTE COMMAND window, press the LEFT arrow key until you have underscored the left most character in the displayed value (ie the A in "A0000"). Use the UP/DOWN arrow keys to increment/decrement the underscored character until it is upper case **N** ("N0000" should appear in the command window). Press the RIGHT arrow key to move the cursor under the most significant digit, then use the UP arrow key to increment it to a value of 6 (the display is now "N6000"). Set the three digits to the right of the 6 to the three digit HFO value from 000 to 255 (corresponding to 0 to 360 degrees) that you calculated above. Use the LEFT/RIGHT keys to underscore the desired digit(s) then use the UP/DONW arrow keys to increment/decrement the underscored value. When you have finished editing the display value, press ENTER to send the HFO value command to the PCU (but it is not save yet).

If you want to find out what the **current** HFO value is key in N6999 and hit **ENTER**.

When completed, you must save the desired HFO value. Press ENTER several times to select the REMOTE PARAMETERS display. Press the LEFT or RIGHT arrow key to enter writing mode and then press the ENTER to save the HFO value in the PCUs NVRAM.

EXAMPLE: In the "Antenna stopped before the Bow" example above, the HFO calculated was 222. To enter this value:

1. Set the Remote Command value to "N6222".
2. Press **ENTER** to send this HFO to the PCU. The display should now show "N0222".
3. When completed, you must save the desired HFO value. Press **ENTER** several times to select the **REMOTE PARAMETERS** display. Press the **LEFT** or **RIGHT** arrow key to

enter writing mode and then press the **ENTER** to save the HFO value in the PCUs NVRAM.

You have to drive the antenna CW in azimuth until the home switch is actuated, or re-initialize the antenna to begin using the new HFO value you have entered and saved. To re-initialize the antenna from the REMOTE COMMAND window of the ACU;

4. Press **UP** arrow key several times to return to the **REMOTE COMMAND** display.
5. Press the **LEFT** or **RIGHT** arrow key to enter edit mode. Use the **LEFT/RIGHT** and **UP/DOWN** arrow keys to set the character and digits to "^0090" and then press the **ENTER** key.

This resets the PCU on the antenna. The antenna will reinitialize with this command (Performs a similar function as a power reset of the antenna) and the new home flag offset value will be used to calibrate the Relative position of the antenna.

5.5. **Radiation Hazard and Blockage Mapping (AZ LIMIT parameters)**

The ACU can be programmed with relative azimuth sectors (zone) where blockage exists or where transmit power would endanger personnel who are frequently in that area.

When the AZ LIMIT parameters are set to create these *ZONES*, up to three, several things happen when the antenna is within one of the zones:

1. Tracking continues as long as the AGC value is greater than the Threshold value. When the AGC value drops below Threshold the antenna will wait "Search Delay" parameter amount of time and then re-target the satellite you targeted last. Timeout and re-target will continue until the satellite is re-acquired and tracking can resume.
2. "BLOCKED" will be displayed in the TRACKING window wherever the antenna is inside one of the zones.
3. A contact closure to ground (or an open if the blockage logic is reversed – See SYSTEM TYPE 16 value) is provided on the SW2 terminal of the Terminal Mounting Strip. This Switch output provides a "Blocked", "RF Radiation Hazard" or "FCC TX Mute" logic output. When the antenna exits the zone it will be on satellite, tracking and the SW2 logic contact closure will open.

The lower and upper limits are user programmable and are stored in NVRAM within the ACU parameter list.

AZ LIMIT 1 is the Lower Relative AZ limit (this is the more counter-clockwise of the two points, even if it is numerically larger). AZ LIMIT 2 is the Upper Relative AZ limit (the more clockwise of the two points) for pattern mapping of ZONE 1.

AZ LIMIT 3 is the Lower Relative AZ limit (CCW point) and AZ LIMIT 4 is the Upper Relative AZ limit (CW point) for pattern mapping of ZONE 2.

AZ LIMIT 5 is the Lower Relative AZ limit (CCW point) and AZ LIMIT 6 is the Upper Relative AZ limit (CW point) for pattern mapping of ZONE 3.



CAUTION: The **Lower** Relative AZ limit is the more **counter-clockwise** of the two points (even if it is numerically larger) and the **Upper** Relative AZ limit is the more clockwise of the two points. If you enter the two relative points incorrectly, Tracking and Searching will be adversely affected.

The ACU provides a contact closure to ground on the SW2 terminal of the Terminal Mounting Strip when the antenna is pointed within any one of the blockage/hazard zones or the system is searching, targeting, unwrapping or is mis-pointed by 0.5 degrees or more (FCC TX Mute function for Transmit/Receive systems **only**). The contact closure is a transistor switch with a current sinking capability of 0.5 Amp.

Refer to your ACU Manual for instructions on how to **simulate** a manual BLOCKED condition to test the SW2 logic output.

When used as simple "**BLOCKED**" logic output for a single Sea Tel antenna, this output could be used to light a remote LED and/or sound a buzzer to alert someone that the antenna is blocked, and therefore signal is lost.

In a "Dual Antenna" installation, this logic output(s) is used to control Dual Antenna Arbitrator panel of coax switches to switch the source inputs to the matrix switch from Antenna "**A**" to Antenna "**B**", and vice versa.

When used as simple "**RF Radiation Hazard**" logic output for a single Sea Tel TXRX antenna, this output is used to suppress RF transmissions while the antenna is pointed where people would be harmed by the transmitted microwave RF power output. The SW2 output would be interfaced to the satellite modem to **disable** the TX output signal from the Satellite TXRX Modem whenever the antenna is within the RF Radiation Hazard zone(s).

When used for "**FCC TX Mute**" logic output for a single Sea Tel TXRX antenna, this output is used to suppress RF transmissions whenever the antenna is mis-pointed 0.5 degrees or more, is blocked, searching, targeting or unwrapping. The SW2 output would be interfaced to the satellite modem to **disable/mute** the TX output signal from the Satellite TXRX Modem. When the mute condition is due to antenna mis-pointing, it will not **un-mute** until the pointing error of the antenna is within 0.2 degrees. The default output is contact closure to ground when the antenna is mis-pointed, therefore provides a **ground** to "Mute" the satellite modem on the SW2 terminal of the Terminal Mounting Strip. If your satellite modem requires an **open** to "Mute", refer to SYSTEM TYPE parameter 16 value to reverse the output logic from the ACU.

Programming instructions:

Determine the Relative AZ positions where blockage, or RF Radiation Hazard, exists. This may be done by monitoring the received signal level and the REL display readings while the ship turns or by graphing the expected blockage pattern. Elevation of the antenna in normal use also must be taken into consideration. A Mast or other structure may cause blockage at low elevation angles, but **may not** cause blockage when the antenna is at higher elevation angles. Up to three zones may be mapped. Only zones which are needed should be mapped (in AZ LIMIT pairs).

In unlimited antenna systems the Relative position of the antenna must have been calibrated by properly setting the Home Flag Offset (HFO) value in the PCU. The HFO calibrates Relative to display 0000 when the antenna is pointed in-line with the bow of the boat/ship (parallel to the bow).

Convert the relative readings to AZ LIMIT values by multiplying by 10. Enter the beginning of the **first** blockage region as AZ LIMIT 1 and the end of the region (clockwise direction from AZ LIMIT 1) as AZ LIMIT 2 parameters in the ACU. If needed, repeat setting AZ LIMIT 3 & 4 for a **second** ZONE and then AZ LIMIT 5 & 6 if a **third** ZONE is needed. All **unneeded** zone AZ LIMIT pairs **must** be set to 0000.

EXAMPLE 1 - Three blockage Zones: A ship has a Sea Tel antenna mounted on the port side and an Inmarsat antenna mounted on the starboard side. A mast forward, the Inmarsat antenna to starboard and an engine exhaust stack aft form the three zones where satellite signal is blocked (as shown in the graphic). In this example zone 1 is caused by the mast, zone 2 is from the Inmarsat antenna and zone 3 is from the stack:

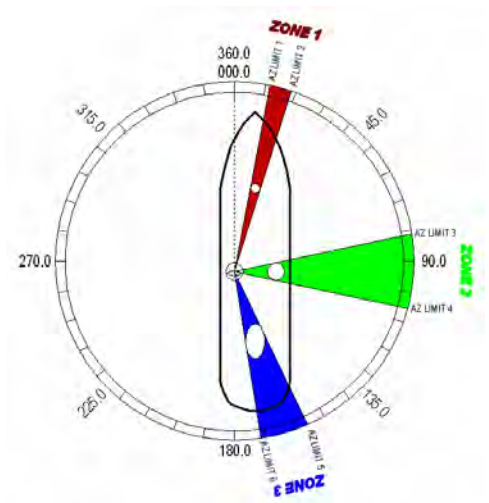

ZONE 1 begins (AZ LIMIT 1) at 12 degrees Relative and ends (AZ LIMIT 2) at 18 degrees Relative.

Multiply these Relative positions by 10. Enter AZ LIMIT 1 value of 0120 and AZ LIMIT 2 value of 0180.

ZONE 2 begins (AZ LIMIT 3) at 82 degrees Relative and ends (AZ LIMIT 4) at 106 degrees Relative.

Multiply these Relative positions by 10. Enter AZ LIMIT 3 value of 0820 and AZ LIMIT 4 value of 1060.

ZONE 3 begins (AZ LIMIT 5) at 156 degrees Relative and ends (AZ LIMIT 6) at 172 degrees Relative. Multiply these Relative positions by 10. Enter AZ LIMIT 5 value of 1560 and AZ LIMIT 6 value of 1720.

EXAMPLE 2 - Three blockage Zones, Dual Antenna configuration: A ship has 2 Sea Tel antennas, "Antenna A" mounted on the port side and "Antenna B" mounted on the starboard side. Antenna A is designated as the **master** antenna.

The mast forward, Antenna B to starboard and the engine exhaust stack aft form the three zones where satellite signal is blocked from Antenna A. The SW2 logic output from Antenna A (ACU A) and Antenna B (ACU B) are used to control a "Dual Antenna Arbitrator" panel of coax switches which route satellite signal from the **un-blocked** antenna to the inputs of the matrix switch. If both antennas are tracking the same satellite, they will not both be blocked at the same time. The logic output will switch to provide satellite signal to the below decks equipment from Antenna A when it is **not blocked** and will switch to provide satellite signal from Antenna B whenever Antenna A **is blocked**.

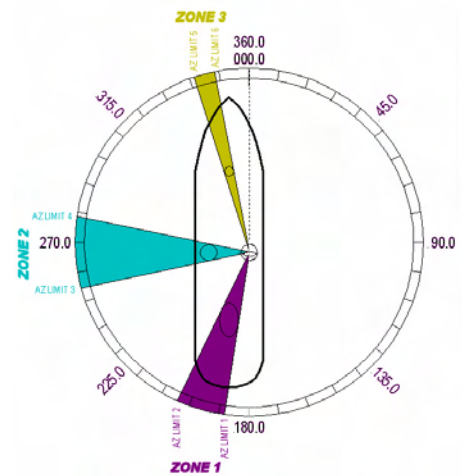

The switches will not change state if **both** antennas are blocked, or if **both** are on satellite.

Antenna A is the same as the previous example and its ACU would be set to those AZ LIMIT values.

Antenna B ACU would be set to:

In this example Antenna B zone 1 is caused by the stack, zone 2 is from Antenna A and zone 3 is from the mast.

ZONE 1 begins (AZ LIMIT 1) at 188 degrees Relative and ends (AZ LIMIT 2) at 204 degrees Relative. Multiply these Relative positions by 10. Enter AZ LIMIT 1 value of 1880 and AZ LIMIT 2 value of 2040.

ZONE 2 begins (AZ LIMIT 3) at 254 degrees Relative and ends (AZ LIMIT 4) at 278 degrees Relative. Multiply these Relative positions by 10. Enter AZ LIMIT 3 value of 2540 and AZ LIMIT 4 value of 2780.

ZONE 3 begins (AZ LIMIT 5) at 342 degrees Relative and ends (AZ LIMIT 6) at 348 degrees Relative. Multiply these Relative positions by 10. Enter AZ LIMIT 5 value of 3420 and AZ LIMIT 6 value of 3480.

EXAMPLE 3 - One blockage Zone: A ship has a Sea Tel antenna mounted on the center line of the ship. A mast is forward and an engine exhaust stack is aft. In this example the Stack does **NOT** block the satellite, only the mast forward does. In this example zone 1 is caused by the mast, zone 2 and zone 3 are not needed:

ZONE 1 begins (AZ LIMIT 1) at 352 degrees Relative and ends (AZ LIMIT 2) at 8 degrees Relative.

Multiply these Relative positions by 10. Enter AZ LIMIT 1 value of 3520 and AZ LIMIT 2 value of 0080.

ZONE 2 is not needed. Enter AZ LIMIT 3 value of 0000 and AZ LIMIT 4 value of 0000.

ZONE 3 is not needed. Enter AZ LIMIT 5 value of 0000 and AZ LIMIT 6 value of 0000.

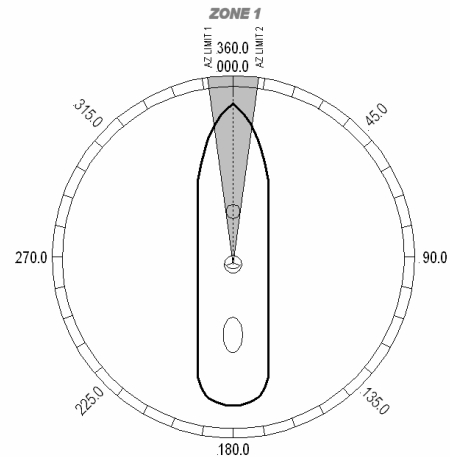

5.6. TX Polarity Setup

To prevent inadvertent switching of the transmit polarity, the user can lock out NS/EW toggle feature and force the transmit polarity to be fixed horizontal or vertical with the TX POLARITY parameter.

With the feed in the center of its polarization adjustment range, observe the transmit port polarity (vector across the short dimension of the transmit wave-guide).

If the transmit polarity in the center of the travel range is vertical, use the following entries:

- 2 Vertical Transmit Polarity
- 4 Horizontal Transmit Polarity

If the Transmit polarity in the center of the travel range is horizontal, use the following entries:

- 2 Horizontal Transmit Polarity
- 4 Vertical Transmit Polarity

5.7. Default Setup Parameters

The following table shows the factory default parameters for the DAC-2200, or DAC-2202, Antenna Control Unit interfaced to a Series 06 Antenna PCU. When the installation & setup of your system is finished you can record the "optimized" settings for your system in the "My Parameters" column. Also refer to the Antenna Control Unit Manual for more in-depth information each of the individual parameters and how to enter, or change, the parameters.

PARAMETER	DishScan	My Parameters
EL TRIM	0	
AZ TRIM	0	
AUTO THRES	60	
EL STEP SIZE	0	
AZ STEP SIZE	0	
STEP INTEGRAL	0	
SEARCH INC	10	
SEARCH LIMIT	100	
SEARCH DELAY	30	
SWEEP INC	0000	
SYSTEM TYPE	69 *	
GYRO TYPE	2 (NMEA/SBS)	
POL TYPE	72	
POL OFFSET	40	
POL SCALE	90	
AZ LIMIT 1	0	
AZ LIMIT 2	0	
AZ LIMIT 3	0	
AZ LIMIT 4	0	
AZ LIMIT 5	0	
AZ LIMIT 6	0	
TX POLARITY	2 (Horizontal TX)	

*** Modem Lock input & Modem TX Mute functions are NOT set, refer to SYSTEM TYPE parameter information.**

This Page Intentionally Left Blank

6. Functional Testing

If not already ON, Turn ON the Power switch on the front panel of the ACU.

6.1. ACU / Antenna System Check

1. Press RESET on the ACU front panel to initialize the system. Verify the display shows "SEA TEL INC - MASTER" and the ACU software version number. Wait 10 seconds for the display to change to "SEA TEL INC - REMOTE" and the PCU software version number.
2. If the display shows "REMOTE INITIALIZING" wait for approximately 2 minutes for the antenna to complete initialization and report the Antenna Model and PCU software version. If "REMOTE NOT RESPONDING" is displayed, refer to the Troubleshooting Section of this manual.
3. Press the **NEXT** key repeatedly to display the **Ship, Satellite, Antenna** and **Status** menu displays. This verifies that the displays change in the correct response to the keys.

6.2. Latitude/Longitude Auto-Update check

This verifies that the GPS position information is automatically updating..

1. Press the **NEXT** key repeatedly to display the **Ship** menu. Press **ENTER** to access edit mode and view the current Latitude value.
2. Press the LEFT arrow key to bring the cursor up under the ones digit, press UP and then hit ENTER. The display should immediately show a latitude value one degree higher, but then will be overwritten within several seconds (back to the previous value) by the GPS engine.

This test does not need to be repeated in the Longitude menu.

6.3. Ship Heading – Gyro Compass Following Check

This verifies that the Heading display is actually following the Ships Gyro Compass.

1. Press the **NEXT** key repeatedly to display the **Ship** menu. If the boat is underway, monitor the Heading value to verify that the display changes in the correct response to the Gyro Compass input (Heading value should always be exactly the same as the Gyro Compass repeater value).
2. If the ship is NOT underway, most ships will turn +/- 1-2 degrees at the pier, monitor the Heading value to verify that the display changes in the correct response to the Gyro Compass input (Heading value should always be exactly the same as the Gyro Compass repeater value).

6.4. Azimuth & Elevation Drive

This verifies that the antenna moves in the correct response to the keys.

1. Press the NEXT key several times to display the Antenna menu.
2. Press the Tracking key to toggle Tracking OFF. Press the UP arrow key repeatedly and verify that the antenna moves up in elevation.
3. Press the DOWN arrow key repeatedly and verify that the antenna moves down in elevation.
4. Press the RIGHT arrow key repeatedly and verify that the antenna moves up (CW) in azimuth.
5. Press the LEFT arrow key repeatedly and verify that the antenna moves down (CCW) in azimuth.

6.5. **Four Quadrant Tracking Test**

This verifies that the antenna moves in the correct response to the keys, that Tracking is signaling correctly and that the Tracking commands are being carried out (antenna drives to peak).

1. Verify antenna is locked onto and tracking a satellite
2. Press the **NEXT** key several times to display the **Antenna** menu.
3. Note the current peak AGC value. Press the **Tracking** key to toggle Tracking OFF, press the **UP** arrow key repeatedly to move the antenna up in elevation until AGC falls about 100 counts. Turn Tracking ON and verify that the antenna moves back down in elevation and that the AGC rises to its' previous high value.
4. Note the current peak AGC value. Press the **Tracking** key to toggle Tracking OFF, press the **DOWN** arrow key repeatedly to move the antenna down in elevation until AGC falls about 100 counts. Turn Tracking ON and verify that the antenna moves back up in elevation and that the AGC rises to its' previous high value.
5. Note the current peak AGC value. Press the **Tracking** key to toggle Tracking OFF, press the **RIGHT** arrow key repeatedly to move the antenna up in azimuth until AGC falls about 100 counts. Turn Tracking ON and verify that the antenna moves back down in azimuth and that the AGC rises to its' previous high value.
6. Note the current peak AGC value. Press the **Tracking** key to toggle Tracking OFF, press the **LEFT** arrow key repeatedly to move the antenna down in azimuth until AGC falls about 100 counts. Turn Tracking ON and verify that the antenna moves back up in azimuth and that the AGC rises to its' previous high value.

6.6. **Blockage Simulation Test**

Blockage output function is used to modify the behavior of Tracking and Searching when there is a known blockage zone. The ACU provides a contact closure to ground on the SW2 terminal of the Terminal Mounting Strip when the antenna is pointed within any one of the blockage/hazard zones or the system is searching, targeting, unwrapping or is mis-pointed by 0.5 degrees or more (FCC TX Mute function for Transmit/Receive systems **only**). The contact closure is a transistor switch with a current sinking capability of 0.5 Amp. This logic output control signal is used for:

- When used as simple "BLOCKED" logic output for a single Sea Tel antenna, this output could be used to light a remote LED and/or sound a buzzer to alert someone that the antenna is blocked, and signal is lost.
- In a "Dual Antenna" installation, this logic output(s) is used to control Dual Antenna Arbitrator panel of coax switches to switch the source inputs to the matrix switch from Antenna "A" to Antenna "B", and vice versa.
- When used as simple "**RF Radiation Hazard**" logic output for a single Sea Tel TX/RX antenna, this output could be used to suppress RF transmissions while the antenna is pointed where people would be harmed by the transmitted microwave RF power output. The SW2 output would be interfaced to the satellite modem to **disable** the TX output signal from the Satellite TXRX Modem whenever the antenna is within the RF Radiation Hazard zone(s).
- When used for "**FCC TX Mute**" logic output for a single Sea Tel TX/RX antenna, this output could be used to suppress RF transmissions whenever the antenna is mis-pointed 0.5 degrees or more, is blocked, searching, targeting or unwrapping. The SW2 output would be interfaced to the satellite modem to **disable/mute** the TX output signal from the Satellite TX/RX Modem. When the mute condition is due to antenna mis-pointing, it will not **un-mute** until the pointing error of the antenna is within 0.2 degrees. The default output is contact closure to ground when the antenna is mis-pointed, therefore provides a **ground** to "Mute" the satellite modem on the

SW2 terminal of the Terminal Mounting Strip. If your satellite modem requires an **open** to "Mute", refer to SYSTEM TYPE parameter 16 value to reverse the output logic from the ACU.

To Test the blockage function:

7. Press the NEXT key until you are at the Status menu. Press ENTER to access the Tracking menu.
8. Press the RIGHT arrow key to bring up and move the cursor to the far right. Press the UP arrow to simulate a manual BLOCKED condition. BLOCKED will appear in the Tracking display.
9. Verify that SW2 terminal shorts to ground (or open circuit if you have SYSTEM TYPE configured to reverse the output logic) and that the external alarms actuate OR the Dual Antenna Arbitrator coax switches toggle (if antenna B is not blocked) OR the Satellite Modem TX is disabled/muted.
10. Press the LEFT arrow key and then press the UP arrow key to turn the simulated blocked condition OFF. BLOCKED will disappear from the Tracking display.
11. Verify that SW2 terminal is open circuit (or ground if you have logic reversed) and that the external alarms deactivate OR the Satellite Modem TX is un-muted. The Dual Antenna Arbitrator coax switches should not toggle until you manually block Antenna B ACU.

6.7. Test Broadband Operation

Open your Internet Browser and access several internet sites, email or other functions as you normally would. Operation should be the same as any equivalent service ashore. The only difference is that the antenna is providing your connection to the Internet through the satellite instead of the connection being provided over the telephone wires.

6.8. Test Voice Over IP (VOIP) Operation





If Voice Over IP equipment has been provided and services are available from your Internet Service Provider (ISP) you should verify that this equipment and service are functioning properly.

Pick up the Telephone handset which is to be used for Voice Over IP telephone calls. Check for voice mail messages and/or place a telephone call (maybe to have them call you back). It is also important to receive a VOIP telephone call by having someone call you or calling yourself from some other telephone system (shore telephone, cellular or Inmarsat).

This Page Intentionally Left Blank

7. Maintenance and Troubleshooting

This section describes the theory of operation to aid in troubleshooting and adjustments of the antenna system. Also refer to the Troubleshooting section of your ACU manual for additional troubleshooting details.

	<p>WARNING: <i>Electrical Hazard – Dangerous AC Voltages exist in the Breaker Box and the Antenna Pedestal Power Supply. Observe proper safety precautions when working inside the Antenna Breaker Box or Power Supply.</i></p>
	<p>WARNING: <i>RF Radiation Hazard - This stabilized antenna system is designed to be used with transmit/receive equipment manufactured by others. Refer to the documentation supplied by the manufacturer which will describe potential hazards, including exposure to RF radiation, associated with the improper use of the transmit/receive equipment. Note that the transmit/receive equipment will operate independently of the stabilized antenna system.</i></p> <p>The ultimate responsibility for safety rests with the facility operator and the individuals who work on the system.</p>
	<p>WARNING: <i>RF Radiation Hazard - Prior to working on the stabilized antenna system, the power to the transmit/receive equipment must be locked out and tagged. Turning OFF power to the Antenna Control Unit does NOT turn Transmit power output OFF.</i></p> <p>The ultimate responsibility for safety rests with the facility operator and the individuals who work on the system.</p>
	<p>WARNING: <i>RF Radiation Hazard - When the transmit/receive system is in operation, no one should be allowed anywhere within the radiated beam being emitted from the reflector.</i></p> <p>The ultimate responsibility for safety rests with the facility operator and the individuals who work on the system.</p>

7.1. Warranty Information

Sea Tel Inc. supports this system with a **ONE YEAR** warranty on Labor and **TWO YEARS** warranty on parts.

What’s Covered by the Limited Warranty?

The Sea Tel Limited Warranty is applicable for parts and labor coverage to the complete antenna system, including all above-decks equipment (radome, pedestal, antenna, motors, electronics, wiring, etc.) and the Antenna Control Unit (ACU).

Factory refurbished components used to replace systems parts under this warranty are covered by this same warranty as the original equipment for the balance of the original warranty term, or ninety (90) days from the date of replacement, whichever occurs last. Original Installation of this system must be accomplished by or under the supervision of an authorized Sea Tel dealer for the Sea Tel Limited Warranty to be valid and in force.

What’s **NOT** Covered by the Limited Warranty?

It does **not** include Transmit & Receive RF Equipment, Modems, Multiplexers or other distribution equipment, whether or not supplied by Sea Tel commonly used in Satellite Communications (TXRX) Systems. These equipments are covered by the applicable warranties of the respective manufacturers.

Should technical assistance be required to repair your system, the first contact should be to the agent/dealer that you purchased the equipment from. Please refer to the complete warranty information included with your system.

7.2. Recommended Preventive Maintenance

Ensure that all of the normal operating settings (LAT, LON, HDG, SAT and all of the Tracking Receiver settings) are set correctly. Refer to the Functional Testing section to test the system.

7.2.1. Check ACU Parameters

Assure that the parameters are set correctly (you may wish to record them in the Factory Default Settings, in section 5 of this manual).

7.2.2. Latitude/Longitude Auto-Update check

Refer to the Latitude & Longitude Update check procedure in the Functional Testing section of this manual.

7.2.3. Heading Following

Refer to the Heading Following verification procedure in the Functional Testing section of this manual.

7.2.4. Azimuth & Elevation Drive

Refer to the Azimuth & Elevation Drive check procedure in the Functional Testing section of this manual.

7.2.5. Test Tracking

Refer to the four quadrant Tracking check procedure in the Functional Testing section of this manual.

7.2.6. Visual Inspection - Radome & Pedestal

Conduct a good, thorough, visual inspection of the radome and antenna pedestal. Visually inspect the inside surface of the radome top and of the antenna pedestal. Look for water or condensation, rust or corrosion, white fiberglass powder residue, loose wiring connections, loose hardware, loose or broken belts or any other signs of wear or damage.

1. Radome Inspection - All the radome flanges are properly sealed to prevent wind, saltwater spray and rain from being able to enter the radome. Re-seal any open ("leaky") areas with marine approved silicone sealant. If heavy condensation, or standing water, is found inside the radome, isolate and seal the leak, and then dry out the radome. Small (1/8 inch) holes may be drilled in the base pan of the radome to allow standing water to "weep" out.
2. Antenna Pedestal Inspection - The springs and Wire Rope Isolators should not be frayed, completely compressed, or otherwise damaged. The plated and painted parts should not be rusted or corroded. The harnesses should not be frayed and all the connectors should be properly fastened and tightened. All hardware should be tight (no loose assemblies or counter-weights). Replace, re-coat, repair and/or tighten as necessary.

7.2.7. Mechanical Checks

To perform the below checks requires that you turn OFF motor drive to all AXIS. This may be accomplished by sending a "n0000" remote command to PCU. For more information on PCU configuration refer to the procedure in section 7.5.

1. Inspect inside of radome for signs that the dish or feed have been rubbing against the inside of the fiberglass radome.
2. Rotate the pedestal through its full range of azimuth motion. The antenna should rotate freely and easily with light finger pressure.
3. Rotate the pedestal through full range of elevation rotation. The antenna should rotate through the full range but offer resistance to rotation in this axis because of the elevation motor brake.
4. Rotate the pedestal through full range of cross-level rotation. The antenna should rotate through the full range but offer resistance to rotation in this axis because of the cross-level motor brake.
5. Rotate the level cage through the full 90 degrees of rotation from CCW stop to CW stop. The level cage antenna should rotate freely and easily with light finger pressure. Attached cables should not cause the cage to spring back more that a few degrees from either stop when released.
6. Inspect all drive belts for wear (black dust on/under the area of the belt).

7.2.8. Check Balance

Check the balance of the antenna, re-balance as needed (refer to the Balancing the Antenna procedure below).

7.2.9. Observe Antenna Initialization

Observe the Antenna Initialization as described in the Troubleshooting section below.

7.3. *Troubleshooting***7.3.1. Theory Of Stabilization Operation**

The antenna system is mounted on a three axis stabilization assembly that provides free motion with 3 degrees of freedom. This assembly allows the inertia of the antenna system to hold the antenna pointed motionless in inertial space while the ship rolls, pitches and yaws beneath the assembly. Three low friction torque motors attached to each of the three free axes of the assembly provide the required force to overcome the disturbing torque imposed on the antenna system by cable restraints, bearing friction and small air currents within the radome. These motors are also used to re-position the antenna in azimuth and elevation.

The Pedestal Control Unit (PCU) uses inputs from the level cage sensors to calculate the amount of torque required in each axis to keep the antenna pointed within +/-0.2 degrees. The basic control loops for Cross Level, Level and Azimuth are shown in the Control Loop Diagram, drawing 116287. The primary sensor input for each loop is the rate sensor mounted in the Level Cage Assembly. This sensor reports all motion of the antenna to the PCU. The PCU immediately responds by applying a torque in the opposite direction to the disturbance to bring the antenna back to its desired position. Both the instantaneous output of the rate sensor (Velocity Error) and the integrated output of the rate sensor (Position Error) are used to achieve the high pointing accuracy specification.

The calculated torque commands are converted to a 5 volt differential analog signal by a Digital to Analog converter (D/A) and sent to each of three Brush-Less Servo Amplifiers. These amplifiers provide the proper drive polarities and commutation required to operate the Brush-Less DC Servo Motors in torque mode. The Torque acting on the mass of the antenna cause it to move, restoring the rate sensors to their original position, and closing the control loop.

Since the rate sensors only monitor motion and not absolute position, a second input is required in each axis as a long term reference to keep the antenna from slowly drifting in position. The Level and Cross Level reference is provided by a two axis tilt sensor in the level cage assembly.

The Azimuth reference is provided by combining the ships gyro compass input and the antenna relative position.

7.3.2. Series 06 TXRX Antenna Initialization

Turn the pedestal power supply ON. The PCU will initialize the stabilized portion of the mass to be level with the horizon and at a prescribed Azimuth and Elevation angles. The antenna will go through the specific sequence of steps (listed below) to initialize the level cage, elevation, cross-level and azimuth to predetermined starting positions.

Initialization is completed in the following phases, each phase must complete properly for the antenna to operate properly (post-initialization). Observe the Initialization of the antenna pedestal.

Step 1. The level platform motor drives the Level Cage CCW, issuing extra steps to assure that the cage is all the way to the mechanical stop. Then the Level Cage will be driven exactly 45.0 degrees CW.

Step 2. Elevation axis then activates - Input from the LV axis of the tilt sensor is used to drive the Elevation of the equipment frame to bring the tilt sensor LV axis to level. This step takes approximately 10 seconds and will result in the dish being at 45.0 degrees in elevation. The level cage may still be tilted left or right at this time.

Step 3. Cross-Level axis activates - Input from the CL axis of the tilt sensor is used to drive Cross-Level of the equipment frame to bring the cross-level axis of the tilt sensor to level (this results in the tilt of the Cross-Level Beam being level). This step takes approximately 10 seconds.

Step 4. Azimuth axis activates - Antenna drives CW in azimuth until the "Home Flag" signal is produced. This signal is produced by a Hall Effect sensor in close proximity to a Magnet. After another 10 second wait, the antenna will report its version number at the Antenna Control Unit (ACU).

This completes the phases of initialization. At this time the antenna elevation should 45.0 degrees and Relative azimuth should be at home flag (home switch hall sensor at the magnet in the azimuth driven sprocket).

If any of these steps fail, or the ACU reports model "**xx03**", re-configure the PCU as described in the Maintenance section of this manual. If initialization still fails, this indicates a drive or sensor problem, refer to the Troubleshooting section.

7.3.3. Antenna Position Error Monitoring

The ACU provides a means for monitoring the position error of the antenna for diagnostic purposes. If this error is excessive, it indicates external forces are acting on the antenna. These forces may be the result of static imbalance, excessive bearing friction, cable binding, or wind loading.

1. To view the position error, select the **REMOTE COMMAND** window on the ACU:
2. Using the **LEFT/RIGHT** and **UP/DOWN** arrow keys set the Remote Command value to "**x0000**" (the x must be lower case) and press **ENTER**.
3. Press **ENTER** key once more to display the **REMOTE MONITOR** window. The lower display will show "iv" and three 4 digit hex numbers (**iv FFFF 0001 FFFD**).

The numbers indicate Cross Level, Level and Azimuth errors at a resolution of 1 part in 65536 or 0.0055 degrees. For example a display like "iv FFFF 0001 FFFD" indicates the Cross Level error is -0.005 degrees, the Level error is + 0.005 degrees and the Azimuth error is -0.016 degrees. The normal range of these numbers is FFF0 to 000F and they typically will bounce around randomly within this range.

7.3.4. Reference Sensor Testing

The ACU provides a means for monitoring the output of the 3 solid state rate sensors and the 3 reference sensors for diagnostic purposes. The rate sensors and reference sensors are the primary inputs to the PCU for stabilization.

1. To view the reference sensors, select the **REMOTE COMMAND** window on the ACU:
2. Using the **LEFT/RIGHT** and **UP/DOWN** arrow keys set the Remote Command value to "**v0000**" (the v must be lower case) and press **ENTER** .
3. Press **ENTER** key once more to display the **REMOTE MONITOR** window. The lower display will show "v" and three 4 digit decimal numbers (**v 1111 2222 3333**).

The numbers represent the Cross Level and Level Tilt Sensor outputs and the azimuth encoder respectively.

The Cross Level Tilt display should be 2048 when the level cage is level. It should decrease when the antenna is tilted to the left and increase when tilted to the right.

The Level tilt display should be 2048 when the level cage is level. It should decrease when the antenna is tilted forward (EL down) and increase when tilted back (EL up).

The Encoder display will show 2048 in the center of the mechanical range (Relative 360.0), decrease in value as the antenna is rotated counter-clockwise (down to about 0102 at lower stop) and increase in value as the antenna is rotated clockwise (up to about 3994 at upper stop).

7.3.5. Open Loop Rate Sensor Test

The ACU provides a means for monitoring the output of the 3 solid state rate sensors and the 3 reference sensors for diagnostic purposes. The rate sensors and reference sensors are the primary inputs to the PCU for stabilization.

1. To monitor the rate sensors, select the **REMOTE COMMAND** window on the ACU:
2. Using the **LEFT/RIGHT** and **UP/DOWN** arrow keys set the Remote Command value to "**w0000**" (the w must be lower case) and press **ENTER**.
3. Press **ENTER** key once more to display the **REMOTE MONITOR** window. The lower display will show "w" and three 4 digit decimal numbers (**w 1111 2222 3333**).

The numbers represent the Cross Level, Level and Azimuth rate sensor outputs respectively each having a nominal display of 2048. The display values will change during movement and return to nominal when movement stops.

The Cross Level display should decrease when the antenna is tilted to the left and increase when tilted to the right.

The Level display should decrease when the antenna is tilted forward and increase when tilted back.

The Azimuth display should decrease when rotated CCW and increase when rotated CW.

7.3.6. Open Loop Motor Test

The ACU provides a means for driving each individual torque motor to test that motors functionality. By driving each axis and observing the resulting motion of the antenna, a coarse operational status of the motor and motor driver can be established.

1. To manually drive the motors, select the **REMOTE COMMAND** window on the ACU:
2. Using the **LEFT/RIGHT** and **UP/DOWN** arrow keys set the Remote Command value to "**^0000**" and press **ENTER**.
3. To drive the Cross Level motor, key in **^1064**, **^1128** or **^1192** and press **ENTER** to drive the Cross Level axis LEFT, OFF or RIGHT respectively.
4. To drive the Level motor, key in **^2064**, **^2128** or **^2192** and press **ENTER** to drive the level axis FORWARD, OFF or BACKWARD respectively.

5. To drive the Azimuth motor, key in \wedge 3064, \wedge 3128 or \wedge 3192 and press **ENTER** to drive the azimuth axis CW, OFF or CCW.

7.3.7. To Disable/Enable DishScan

To be able to use Step Track, or to revert to Conscan, as your active tracking mode you will have to disable DishScan.

Select the **DISHSCAN** parameter window on the ACU:

1. Press the RIGHT arrow, then press the UP arrow and last press the ENTER key to turn DishScan mode ON.
2. Press the RIGHT arrow, then press the DOWN arrow and last press the ENTER key to turn DishScan Mode OFF.

If you change this remote parameter, you must save the change using REMOTE PARAMETERS.

If DishScan is **OFF** and the **Step Integral** parameter is set to **0000**, you will get a **constant ERROR 0016** (DishScan error) and you will see **zeros** flashing in the lower left of the Azimuth and Elevation ENTRY menu displays. This is a visual indication that DishScan is turned OFF.

7.3.8. Satellite Reference Mode

The ships gyro compass input to the ACU may be accurate and stable in static conditions and yet may NOT be accurate or stable enough in some underway dynamic conditions. If there is no gyro compass or if the input is corrupt, not stable or not consistently accurate the tracking errors will become large enough to cause the antenna to be mis-pointed off satellite.

Satellite Reference Mode will uncouple the gyro reference from the azimuth rate sensor control loop. When operating in Satellite Reference Mode changes in ships gyro reading will not directly affect the azimuth control loop. The Pedestal Control Unit will stabilize the antenna based entirely on the azimuth rate sensor loop and the tracking information from DishScan. This will keep the azimuth rate sensor position from eventually drifting away at a rate faster than the tracking loop can correct by using the tracking errors to regulate the rate sensor bias.

Satellite Reference Mode can be used as a diagnostic mode to determine if tracking errors are caused by faulty gyro inputs.

Satellite Reference Mode ***MUST be used when:***

- No Gyro Compass is available
- Frequent or constant ACU Error Code 0001 (Gyro Compass has failed)
- Gyro Compass output is NMEA heading
- Flux Gate Compass is being used
- GPS Satellite Compass is being used

To view, or change, the Satellite Reference Mode status, select the SAT REF remote parameter:

3. Press the RIGHT arrow, then press the UP arrow and last press the ENTER key to turn Satellite Reference Mode ON.
4. Press the RIGHT arrow, then press the DOWN arrow and last press the ENTER key to turn Satellite Reference Mode OFF.

If you change this remote parameter, you must save the change using REMOTE PARAMETERS.

7.3.9. To Read/Decode an ACU Error Code 0008 (Pedestal Error):

Select the REMOTE COMMAND window on the ACU and;

1. Using the **LEFT/RIGHT** and **UP/DOWN** arrow keys set the Remote Command value to **"S0000"** (the S must be upper case) and press **ENTER**.
2. Press **ENTER** key once more to display the **REMOTE MONITOR** window. **SABC@** will be displayed (S followed by 3 letters and a symbol (checksum). The fourth letter (**C**

above) is the pedestal error letter. **Ref** is an AZ Reference, encoder or Home Flag error. **AZ** is Azimuth, **LV** is Level (Elevation) and **CL** is Cross-Level. Decode the letter code using the chart below:

Letter	REF	AZ	LV	CL	Description of Pedestal Error
@	0	0	0	0	None
A	0	0	0	1	CL
B	0	0	1	0	LV
C	0	0	1	1	CL + LV
D	0	1	0	0	AZ
E	0	1	0	1	AZ + CL
F	0	1	1	0	AZ + LV
G	0	1	1	1	AZ + LV + CL
H	1	0	0	0	Ref
I	1	0	0	1	Ref + CL
J	1	0	1	0	Ref + LV
K	1	0	1	1	Ref + LV + CL
L	1	1	0	0	Ref + AZ
M	1	1	0	1	Ref + AZ + CL
N	1	1	1	0	Ref + AZ + LV
O	1	1	1	1	Ref + AZ + LV + CL
P	0	0	0	0	Stab Limit
Q	0	0	0	1	Stab Limit + CL
R	0	0	1	0	Stab Limit + LV
S	0	0	1	1	Stab Limit + CL + LV
T	0	1	0	0	Stab Limit + AZ
U	0	1	0	1	Stab Limit + AZ + CL
V	0	1	1	0	Stab Limit + AZ + LV
W	0	1	1	1	Stab Limit + AZ + LV + CL
X	1	0	0	0	Stab Limit + Ref
Y	1	0	0	1	Stab Limit + Ref + CL
Z	1	0	1	0	Stab Limit + Ref + LV
[1	0	1	1	Stab Limit + Ref + LV + CL
\	1	1	0	0	Stab Limit + Ref + AZ
]	1	1	0	1	Stab Limit + Ref + AZ + CL
^	1	1	1	0	Stab Limit + Ref + AZ + LV
_	1	1	1	1	Stab Limit + Ref + AZ + LV + CL

7.3.10. Get Remote GPS LAT/LON Position:

The remote command in the DAC-2200 to get the position from the GPS antenna mounted on the antenna pedestal is @0000.

To send this remote command to the PCU;

1. Select the REMOTE COMMAND window on the ACU and;
2. Press the LEFT arrow key to bring up the cursor and move it to the left until the current symbol in front of the 0000 is underscored.
3. Increment or decrement the symbol using the UP & DOWN arrow keys until the @ character followed by four zeros is displayed.
4. Press the ENTER key to send the command to the PCU.
5. Press ENTER, or the DOWN arrow key, to access the REMOTE MONITOR. The GPS Latitude & Longitude position and status will be displayed on the bottom line of the display.

The Latitude & Longitude position of the GPS will be displayed in the following format:

@ LAT,N,LON,E,A & where LAT and LON are in degrees and minutes, LAT will be followed by N or S (North or South), LON will be followed by E or W (East or West), then a status character and finally a checksum character. Furuno default value is in Japan at 34.4N 135.2E (@3444,N,13521,E,,_). After acquiring a good fix at Sea Tel the string is @3800,N,12202,W,A^ for our 38N 122W Latitude and Longitude position.

The status character tells you the status of the GPS. Comma = GPS has NOT acquired a fix, N = GPS fix is NOT valid and A = GPS has acquired a valid fix.

As a test, if a valid fix is being viewed in the Remote Monitor window and the GPS antenna cable is unplugged from the PCU, the status character which was an A should become an N within 5 seconds.

7.4. *Maintenance***7.4.1. Balancing the Antenna**

The antenna and equipment frame are balanced at the factory however, after disassembly for shipping or maintenance, balance adjustment may be necessary. Balancing must be done with the power supply turned OFF. No belt removal is required to balance the antenna pedestal. Balancing is accomplished by adding or removing balance trim weights at strategic locations to keep the antenna from falling forward/backward or side to side. The antenna system is not pendulous so 'balanced' is defined as the antenna remaining at rest when left in any position. The antenna should be balanced within one or two ounces at the typical trim weight location of 2 feet from the axis of rotation.

The recommend balancing order is Elevation Axis with the antenna pointed at the horizon (referred to as front to back balance). Elevation Axis with the antenna pointed at zenith (referred to as top to bottom balance). Then Cross Level axis at any elevation position (referred to as side to side balance). The balance about azimuth axis is accomplished by accurately positioning the cross level beam in the azimuth stabilization assembly. This adjustment is done at the factory using special alignment tools. Do NOT attempt to adjust the cross level beam position in the field without the proper test fixtures.

7.4.2. 24 VDC Polang Alignment

1. Select the POL TYPE parameter under the MODE/SETUP display and change the POL type setting to 9 (8+1). Press ANTENNA key 3 times to select the POL display. Rotate the feed using the UP and DOWN keys so that the feed is in the CENTER of its range and the ports are aligned Horizontal and Vertical (Align the metal patches horizontally and

vertically on an HCDC feed with the Ku band LNB at 2 o'clock). This is the Center Reference position.

2. Verify the POL display reads 120 +/-10. Adjust the potentiometer on the feed if necessary to bring this reading into spec (2.5v for xx96/xx97 systems). Note the display reading as the Center Reference value.
3. Rotate the feed CW 90 degrees viewed looking towards the satellite (CCW looking into the dish) by pressing the UP key. The display reading must have INCREASED. Record the change in the POL display reading from the Center Reference value. The change must be 60 or 90. If it is any other value, there is a problem with the Polang potentiometer scale settings and should be corrected for proper operation.
4. Rotate the feed CCW 180 degrees or as far as it will travel, viewed looking towards the satellite (CW looking into the dish). If the feed allows full 180-degree rotation, the POL display will show 60 or 90 counts below the center reference value. Enter this value as the POL OFFSET parameter and the value recorded in step 3 as the POL SCALE parameter under the MODE/SETUP window.

NOTE: If the feed does not allow a full 180 degree rotation to the CCW position, (CW looking into the dish), move the feed as far as it will go and readjust the Polang potentiometer setting so the POL display shows 30-32. Move the feed to the center position and note the new reading. Calculate the POL OFFSET as the Center minus POL SCALE value and enter in the DAC-97 parameter list.

5. Align the feed for optimum polarization with the UP/DOWN keys and note the POL display. Select the POL TYPE parameter again and change the POL TYPE to 72 (64+8) to enable auto pol. If the POL position is not optimum using auto pol, trim the POL position up or down by adjusting the POL OFFSET parameter.

7.4.3. To Adjust Tilt:

Select the REMOTE TILT window on the ACU and;

1. Using the **LEFT/RIGHT** and then press **ENTER**.
2. Set a bubble (or bulls-eye) level on top of the Level Cage assembly. **NOTE:** If the level cage is not within 4 degrees of level fore/aft or left/right, replace the Level Cage assembly.
3. If the level cage is within 4 degrees, use the **UP/DOWN** arrow keys to adjust LV (fore/aft) until the level cage is level in this axis.
4. If the level cage is within 4 degrees, use the **LEFT/RIGHT** arrow keys to adjust CL (left/right) until the level cage is level in this axis.
5. Once the level cage is level in both axes, wait for 30 seconds then press the **ENTER** key.
6. Press **ENTER** to step the menu to **REMOTE PARAMETERS**.
7. Press the **LEFT** arrow key and then press the **ENTER** key to save the settings in the PCU.

This saves the new tilt bias settings in the PCU. Reset or re-initialize the antenna to verify that the Level cage is properly level with the new settings.

7.4.4. To Reset/Reinitialize the Antenna:

To Re-initialize the antenna from the **REMOTE COMMAND** window on the ACU:

1. Using the **LEFT/RIGHT** and **UP/DOWN** arrow keys set the Remote Command value to "**^0090**" and press **ENTER**.

This resets the PCU on the antenna. The antenna will reinitialize with this command (Performs a similar function as a power reset of the antenna).

7.4.5. Switching Cross-Pol/Co-Pol Receive Output from the Antenna:

Your antenna can provide Co-Pol, or Cross-Pol, receive signal to your modem.

A Cross-Pol LNB is installed on the receive port of the feed assembly and its' output coax is routed to the pedestal modem (labeled "Cross-Pol"). A diplexer is installed in the TX waveguide between the BUC and the TX port of the feed assembly. A Co-Pol LNB is installed on the RX output of the diplexer and its' output coax is routed to the pedestal modem (labeled "Co-Pol").

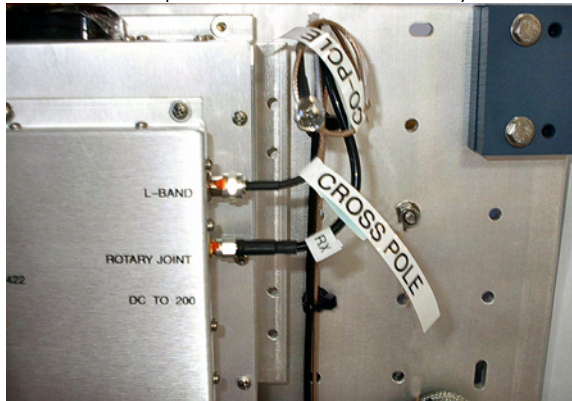

You must select which output you want to be sent to the below decks (Co-Pol or Cross-Pol):

1. Open the radome hatch and set it aside inside the radome.
2. Reach in the hatch opening and turn antenna power OFF (to assure that the antenna is not transmitting when you enter the radome).
3. Climb up so that your upper torso is in the hatch of the radome and rotate the antenna so the dish is at (or near) horizon and is pointed to your right. This will position the right side of the antenna pedestal to be in front of you (as seen in the picture).
4. If Co-Pol receive signal is needed, plug the "Co-Pol" coax into the pedestal modem.
5. If Cross-Pol receive signal is needed, plug the "Cross-Pol" coax into the pedestal modem.
6. Climb down out of the hatch, turn antenna power ON, put the hatch back in place and secure it.

The antenna will reinitialize when you turn the power ON. The ACU provides DC power to the LNB you have plugged into the pedestal modem via the coax rotary joint.

7.5. Pedestal Control Unit Configuration – Series 06

The PCU is designed to be used with a variety of antenna pedestal models. So, the PCU must be configured correctly for the model number of the antenna it is mounted on. The configuration information that is unique to each pedestal model is stored in a Non Volatile Random Access Memory (NVRAM) in the PCU enclosure. If the PCU is replaced or the NVRAM in the PCU should become corrupt, the PCU must be re-configured to operate with the pedestal it is installed on. The default configuration for the PCU is model **xx03, xx04 or xx06**. *In this configuration the Level Cage will drive normally but the PCU will not drive any of the three torque motors to prevent damage to the unknown pedestal.*

7.5.1. To configure the PCU:

1. Select the REMOTE COMMAND window on the ACU.
2. Refer to the table below to key in the appropriate value for you model antenna to enter in the next step. **EXAMPLE:** For a **4006** Model Antenna, select system type 0020.
3. Using the **LEFT/RIGHT** and **UP/DOWN** arrow keys set the Remote Command value to "**N0020**" and press **ENTER**. The display should now show "N0020".
4. Press **ENTER** several times to select **REMOTE PARAMETERS**. Press **LEFT** arrow and then **ENTER** to save the system type in the PCU.
5. Press **RESET** and the displayed Remote Version Number should now display "**4006** VER 2.nn".

7.5.2. Model Configuration Numbers

The following table shows the current mode configuration values for Series 06 pedestals.

MODEL	Configuration Number
xx03/xx06	N 0000 Turns off all drive motors
4006	N 0020
4006H (4006-10)	N 0021
6006 Ku	N 0022
6006 C	N 0023

7.6. Antenna Stowing Procedure



WARNING: Antenna Pedestal **must be properly restrained (stowed)** to prevent damage to wire rope isolators, isolator springs and/or antenna pedestal mechanism during underway conditions **when power is removed from the antenna assembly.**

The normal operating condition for the Sea Tel Antenna system is to remain powered up at all times. This ensures that the antenna remains actively stabilized to prevent physical damage to the antenna pedestal and reduce condensation and moisture in the radome to prevent corrosion. If, for some reason, the antenna must be powered down during underway transits, it should be secured with nylon straps regardless of sea conditions to prevent damage to the antenna system. Refer to the procedure below to secure the antenna pedestal.

Equipment & Hardware needed:

- Two (2) Nylon web straps with buckle or ratchet mechanism. **Nylon straps should be rated to 300 lbs. Max rated capacity.**

Stowing procedure:

1. Point the antenna to Zenith, (90 degree elevation angle), straight up.
2. Install one strap through the hole in one side elevation beam, down under the upper base plate, through the other elevation beam hole or standoff. Cinch or ratchet the web strap to just restrain the antenna.

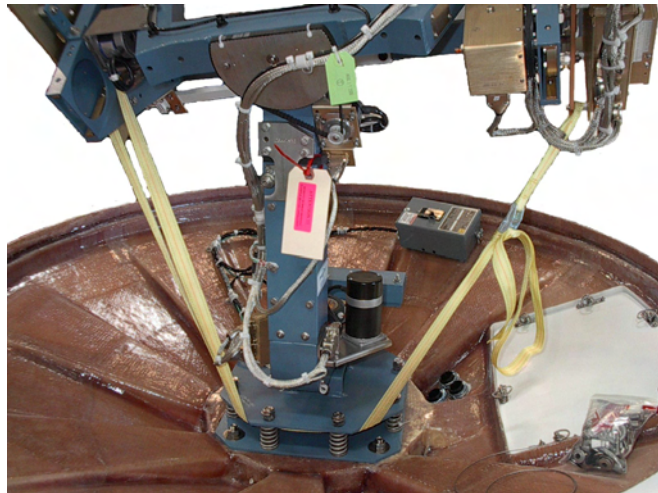

CAUTION: Tighten the straps **ONLY** tight enough to restrain the antenna. When restrained the antenna will only be able to move about an inch in any direction. **DO NOT OVER-TIGHTEN.**



NOTE: Remove the straps, and/or Tiewraps, **before applying power** and returning the antenna to normal operating condition.

8. 4006-33 Technical Specifications

The specifications of your 4006 antenna system are below.

8.1. Antenna Reflector/Feed 4006

Type	Spun Aluminum axis symmetric reflector
Size	40 inch (101.6cm)
Feed	Center focus Cassegrain feed with Co-Pol or Cross-Pol OMT
LNB (s)	Single output Linear LNBS can be provided; for 10.95-11.7 GHz, 11.7-12.2 GHz or 12.2-12.75 GHz frequency bands.
Polarization	Linear TX and dual linear RX w/motorized skew adjustment
Polarization control	24 volt DC motor with pot feedback
Antenna Gain	
TX Gain	40 dBi at 14.0 GHz Typical
RX Gain	39 dBi at 12.5 GHz Typical
Transmit frequency range	14.0-14.5 GHz Ku Band
Receive frequency range	10.95-12.75 GHz Ku Band

8.2. TX Radio Package

SSPBUC (Block Up-Converter)	8 Watt SSP BUC
Transmit Diplexer	DPX75K-002
Transmit Input	WR-75 Flange, 13.75-14.5 GHz
Transmit Output	WR-75 Flange, 13.75-14.5 GHz
Receive Output	WR-75 Flange, 10.95-12.75 GHz

8.3. Pedestal Control Unit

The PCU Assembly contains 2 Printed Circuit Boards (PCBs). One is the main control board and the other is the Motor Driver for the 3 Brushless DC Drive motors (AZ/EL/CL).

Connectors	
Antenna Pedestal	44 Pin D-Sub connector
Motor Interface	25 Pin D-Sub connector
M&C Interface	15 Pin D-Sub connector
GPS Input	BNC connector
Controls	None
M&C Interface	9600 Baud RS-422

8.4. Unlimited Azimuth Modem/Multiplexer (3 Channel)

Combined Signals (-1,-2)

Pass-Thru	70, 140, 950-2050 MHz RX IF, 22Khz Tone DC LNB Voltage Select
Injected	1.1 / 1.5Mhz Pedestal M&C

Connectors:

RX IF	F female
Rotary Joint	SMA female
DC / Ped M&C	9 pin D-Sub Connector

Pedestal M&C

Modulation	FSK
Mode	Full Duplex
Frequencies	1.1/1.5 MHz

Combined Signals (-5)

Pass-Thru	70, 140, 950-2050 MHz RX IF, 22Khz Tone
-----------	--

Injected	1.1 / 1.5Mhz Pedestal M&C DC LNB Voltage Select
----------	--

Connectors:

RX IF	F female
Rotary Joint	SMA female
DC / Ped M&C	9 pin D-Sub Connector

Pedestal M&C

Modulation	FSK
Mode	Full Duplex
Frequencies	1.1/1.5 MHz

8.5. Stabilized Antenna Pedestal Assembly

Type:	Three-axis (Level, Cross Level, AZ)
Stabilization:	Torque Mode Servo
Stab Accuracy:	0.3 degrees MAX, 0.15 degrees RMS in presence of specified ship motions (see section 1.8).
LV, CL, AZ motors:	Size 23 Brushless DC Servo.
Inertial Reference:	Solid State Rate Sensors
Gravity Reference:	Two Axis Fluid Tilt Sensor
AZ transducer:	256 line optical encoder / home switch
Pedestal Range of Motion:	
Elevation	-20 to +115
Cross Level (Inclined 30 degrees)	+/- 35 degrees
Azimuth	Unlimited
Elevation Pointing	+5 to +90 degrees at maximum specified roll +10 to +85 degrees at maximum combined roll & pitch
Specified Ship Motions (for stabilization accuracy tests):	
Roll:	+/-20 degrees at 8-12 sec periods
Pitch:	+/-10 degrees at 6-12 sec periods
Yaw:	+/-8 degrees at 15 to 20 sec periods
Turning rate:	Up to 12 deg/sec and 15 deg/sec/sec
Headway:	Up to 50 knots
Mounting height:	Up to 150 feet.
Heave	0.5G
Surge	0.2G
Sway	0.2G
Maximum Specified Ship Motions	
Roll	+/- 24 degrees
Pitch	+/- 14 degrees
Yaw	Unlimited

8.6. Radome Assembly, 50"

Type/Material:	Rigid fiberglass dome
Material:	Composite foam/fiberglass
Size:	
Diameter:	51.75 inches (131.3 cm)
Height:	59 inches (149.9 cm) MAX
Installed weight	250 pounds MAX including antenna
RF attenuation:	1.5 dB at 12 GHz, dry 1.5 dB @ 14 GHz, dry
Wind:	Withstand relative average winds up to 100 MPH from any direction.
Ingress Protection Rating	All Sea Tel radomes have an IP rating of 56

***NOTE: Radome panels can absorb up to 50% moisture by weight. Soaked panels will also have higher attenuation.**

8.7. ADE Pedestal Power Requirements:

Antenna AC Input Power	110/220 VAC, 60/50 Hz, single phase
Antenna Power Consumption	100 Watts MAX

8.8. Environmental Conditions (Above Decks Equipment)

Temperature:	-20 degrees C to 55 degrees C.
Humidity:	Up to 100% @ 40 degrees C., non-condensing.
Spray:	Resistant to water penetration sprayed from any direction.
Icing:	Survive ice loads of 4.5 pounds per square foot. Degraded RF performance will occur under icing conditions.
Rain:	Up to 4 inches per hour. Degraded RF performance may occur when the radome surface is wet.
Wind:	Withstand relative average winds up to 100 MPH from any direction.
Vibration:	Withstand externally imposed vibrations in all 3 axes, having displacement amplitudes as follows:
Frequency Range, Hz	Peak Single Amplitude
4 - 10	0.100 inches (0.16 to 1.0G)
10 - 15	0.030 inches (0.3 to 0.7G)
15 - 25	0.016 inches (0.4 to 1.0G)
25 - 33	0.009 inches (0.6 to 1.0G)
Corrosion	Parts are corrosion resistant or are treated to endure effects of salt air and salt spray. The equipment is specifically designed and manufactured for marine use.

8.9. Below Decks Equipment

8.9.1. DAC-2202 Antenna Control Unit (ACU)

Refer to the DAC-2202 Manual for its specifications.

8.9.2. Terminal Mounting Strip (TMS)

Refer to the DAC-2202 Manual for the TMS specifications.

8.9.3. Satellite Modem

Please refer to the manufacturers I&O manual for this device.

8.9.4. Router

Please refer to the manufacturers I&O manual for this device.

8.10. Cables

8.10.1. Antenna Control Cable (Provided from ACU-MUX)

RS-422 Pedestal Interface

Type	Shielded Twisted Pairs
Number of wires	4
Wire Gauge	24 AWG or larger
Communications Parameters:	9600 Baud, 8 bits, No parity
Interface Protocol:	RS-422
Interface Connector:	DE-9P

8.10.2. Antenna L-Band IF Coax Cables (Customer Furnished)

Due to the loss across the length of the RF coaxes at L-Band, Sea Tel recommends the following coax cable types (and their equivalent conductor size) for our standard pedestal installations:

Run Length	Coax Type	Conductor Size
up to 35 ft	RG-59	20 AWG
up to 75 ft	RG-6	18 AWG
up to 150 ft	RG-11	14 AWG
up to 200 ft	LMR-500	10 AWG
Up to 300 ft	LMR-600	6 AWG

8.10.3. Multi-conductor Cables (Customer Furnished)

Due to the voltage loss across the multi-conductor cables, Sea Tel recommends the following wire gauge for the AC & DC multi-conductor cables used in our standard pedestal installations:

Run Length	Conductor Size
up to 50 ft	20 AWG (0.8 mm)
up to 100 ft	18 AWG (1.0 mm)
up to 150 ft	16 AWG (1.3 mm)
up to 250 ft	14 AWG (1.6 mm)
Up to 350 ft	12 AWG (2.0 mm)

8.10.4. AC Power Cable Above Decks (Customer Furnished)

Voltage:	110 or 220 volts AC, 50/60 Hz., single phase
Type:	Multi-conductor, Shielded
Number of wires	3 Conductors
Wire Gauge:	See Multi-conductor Cables spec above
Insulation:	600 VAC

8.10.5. Gyro Compass Interface Cable (Customer Furnished)

Type:	Multi-conductor, Shielded
Number of wires	4 Conductors for Step-By-Step, 5 Conductors for Synchro
Wire Gauge:	See Multi-conductor Cables spec above
Insulation:	600 VAC

9. DRAWINGS

The drawings listed below are provided as part of this manual for use as a diagnostic reference.

9.1. 4006-33 Ku-Band Model Specific Drawings

Drawing	Title	
126951-2_A1	System, 4006-33	9-3
126678-2_B	System Block Diagram, 4006-33	9-5
126942-2_B	General Assembly, 4006-33	9-8
126677_A5	Antenna System Schematic	9-11
123511-1_A	4006 Antenna Assembly	9-12
125622-1_C	50" Radome Assembly	9-14
122663_B4	Installation Arrangement	9-17

9.2. 4006 General Drawings

Drawing	Title	
125093-1_A	Standard Spare Parts Kit	9-18
125094-1_A	Premium Spare Parts Kit	9-19
125095-1_A	Master Spare Parts Kit	9-20
124348_B1	Pedestal Harness Schematic	9-21
121628-4_L	Terminal Mounting Strip	9-22
116881-16_C	Base Multiplexer Panel	9-27

This Page Intentionally Left Blank

SINGLE LEVEL MFG BILL OF MATERIAL

FIND	QTY	PART NO	REV	DESCRIPTION	REFERENCE DESIGNATOR
1	1 EA	126942-2	B	GENERAL ASS'Y, 4006RZ-33 & 35, STD LN	
2	1 EA	125622-1	C	RADOME ASS'Y, 4003/4006 GA INSTALL, 5	
4	0 EA	124167-4	B2	SSPB, KU-BAND, CODAN LBUC, 8W, 48VD	(SEE SALES ORDER)
5	0 EA	122188-1	A3	LNB, 11.70 TO 12.20 GHz, PLL, +/- 3 ppm, T	(SEE SALES ORDER)
5	0 EA	122188-2	A3	LNB, 12.25 TO 12.75 GHz, PLL, +/- 3 ppm, T	(SEE SALES ORDER)
5	0 EA	122188-3	A3	LNB, 10.95 TO 11.70 GHz, PLL, +/- 3 ppm, T	(SEE SALES ORDER)
6	1 EA	125411-2	C	DAC-2202, DVB RCVR, 9 WIRE IF	(NOT SHOWN)
7	1 EA	123752-5	D	BELOW DECK KIT, L-BAND, PED & RF M&C	(NOT SHOWN)
8	0 EA	121731		(REF, SEE DASH) CABLE ASS'Y, LMR-400,	(SEE SALES ORDER)
9	1 EA	123520-15		CUSTOMER DOC PACKET, 4006-33, 50 IN	(NOT SHOWN)
11	1 EA	124747-1	A	DECAL KIT, SEATEL, 4006	(NOT SHOWN)
12	1 EA	121711	A	BALANCE WEIGHT KIT	(NOT SHOWN)
13	1 EA	123324-1	B1	SHIP STOWAGE KIT, XX06	(NOT SHOWN)

				
SYSTEM, 4006RZ-33, 50 INCH RADOME				
PROD FAMILY 4006	EFF. DATE 20-Nov-07	SHT 1 OF 1	DRAWING NUMBER 126951-2	REV A1

NOTES, UNLESS OTHERWISE SPECIFIED:

1. APPLY ADHESIVE PER SEA TEL SPEC 121730.

REVISION HISTORY				
REV	ECO#	DATE	DESCRIPTION	BY
A	N/A	08/08/07	RELEASE TO PRODUCTION, NO PRIOR REVISION.	KRB
A1	N/A	08/20/07	ADDED DASH TABLE.	KRB

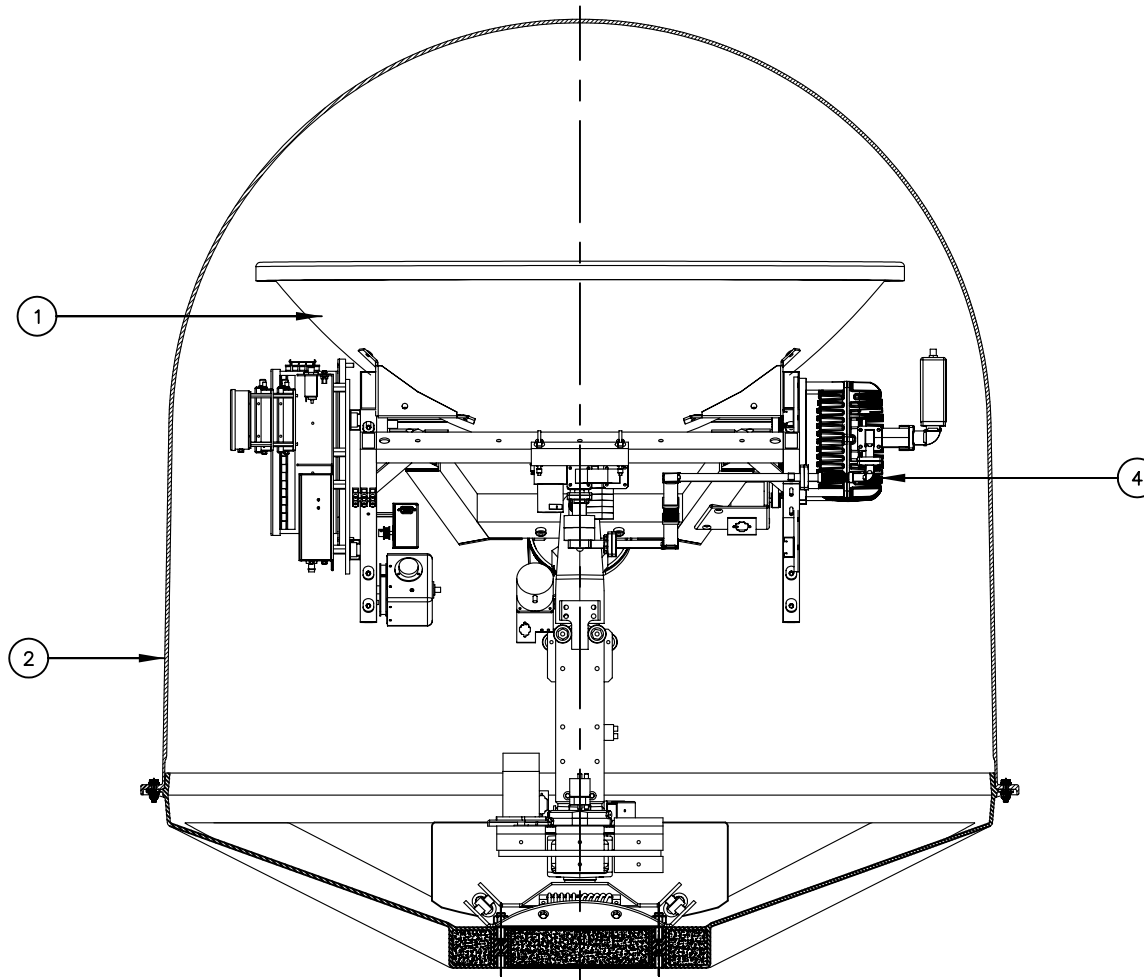
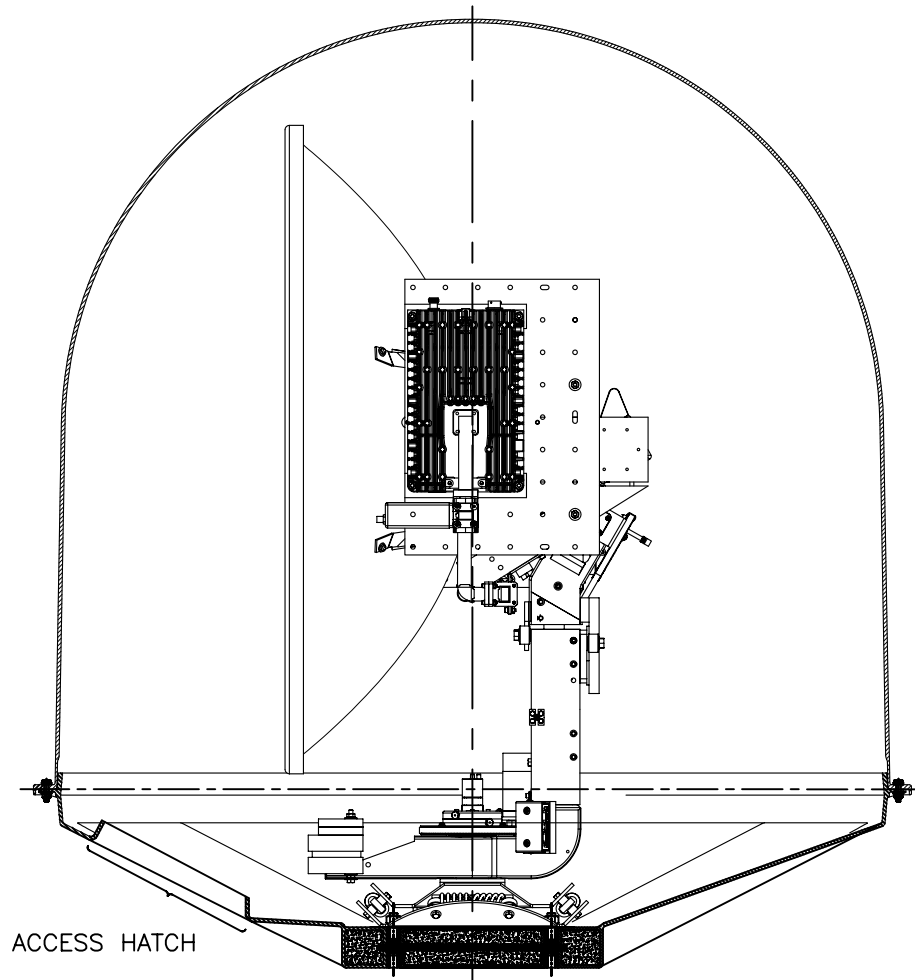

REFERENCE DRAWINGS:

- 126678 SYSTEM BLOCK DIAGRAM.
- 126677 ANTENNA SYSTEM SCHEMATIC.
- 124348 PEDESTAL ANTENNA SCHEMATIC.
- 122663 INSTALLATION ARRANGEMENT.

DASH #	DESCRIPTION
-1	POWER LNB
-2	STANDARD LNB

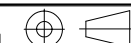
TOLERANCES UNLESS OTHERWISE SPECIFIED		DRAWN BY: KRB		 4030 NELSON AVENUE CONCORD, CA 94520 Tel. 925-798-7979 Fax. 925-798-7986	
X.X = ±.050 X.XX = ±.020 X.XXX = ±.005 ANGLES: ±.5° INTERPRET TOLERANCING PER ASME Y14.5M - 1994		DRAWN DATE: 08/08/07			
MATERIAL: NA		APPROVED BY:		TITLE: SYSTEM, 4006RZ-33	
FINISH: NA		APPROVED DATE:		50 INCH RADOME	
3rd ANGLE PROJECTION 		SIZE: B	SCALE: 1:12	DRAWING NUMBER: 126951	REV: A1
FIRST USED: 4006RZ				SHEET NUMBER: 1 OF 1	

SINGLE LEVEL MFG BILL OF MATERIAL

FIND	QTY	PART NO	REV	DESCRIPTION	REFERENCE DESIGNATOR
1	1 EA	126942-1	B	GENERAL ASS'Y, 4006RZ-33 & 35, LNB PO	
2	1 EA	125622-1	C	RADOME ASS'Y, 4003/4006 GA INSTALL, 5	
4	1 EA	123329-1	E	FEED ASS'Y, KU, CROSS-POLAR, W/ROTA	
5	1 EA	122188		(REF ONLY, SEE DASH) LNB, KU-BAND, PL	
6	1 EA	124167-4	B2	SSPB, KU-BAND, CODAN LBUC, 8W, 48VD	
7	1 EA	125755-1	C	POWER SUPPLY ASS'Y, 48V, 300W	
18	1 EA	117168-5	L1	MODEM ASS'Y, PEDESTAL, 3-CH. 75 OHM	
19	1 EA	117611-3	G	MODEM ASS'Y, PEDESTAL, 3 CH. -200, 50	
20	1 EA	115708-1	L	CIRCUIT BREAKER BOX ASS'Y, 220V	
21	1 EA	125570-2	D1	POWER SUPPLY ASS'Y, COSEL 150W, RH	
22	1 EA	123845-1	B	PCU ENCLOSURE ASS'Y, 06	
23	1 EA	116024-5	J2	SHIELDED POLANG RELAY ASS'Y	
24	1 EA	121966-2	D	GPS ANTENNA, RETERMINATED, 21.0 L	
25	1 EA	124121-1	A1	HALL EFFECT ENCLOSURE ASS'Y	
26	1 EA	122937-1	F1	LEVEL CAGE ASS'Y, BOTTOM EXIT, 90 DE	
30	1 EA	121485-3	F	HARNESS ASS'Y, REFLECTOR	
31	1 EA	124213-2	C1	HARNESS ASS'Y, 3BLDC, XX06	
32	1 EA	122223-3	E	HARNESS ASS'Y, PEDESTAL, REFERENC	
33	1 EA	121425-3	D2	HARNESS ASS'Y, INTERFACE, 4006	
34	1 EA	125476-4	A3	HARNESS ASS'Y, M & C, ADD-ON, CODAN	
35	1 EA	126271-1		CABLE ASS'Y, CODAN, DC POWER, BUC	(PART OF ITEM #6)
36	1 EA	124288-36	D	CABLE ASS'Y, AC POWER, 36 IN	
37	1 EA	125460-64	B	CABLE ASS'Y, PEDESTAL AC POWER 4006	
38	1 EA	108929-2	C1	POWER CORD, 110V AC	(PART OF ITEM #7)
40	2 EA	117164-60BLK	A4	CABLE ASS'Y, RG-179 COAX, F TO F, 60 IN	
41	1 EA	111079-8	G	CABLE ASS'Y, SMA(M)-N(M), 8 FT.	
42	1 EA	114972-9	L	CABLE ASS'Y, SMA(M) - SMA(M), 6 IN	
43	1 EA	114972-3	L	CABLE ASS'Y, SMA(M) - SMA(M), 84 IN	
44	2 EA	114972-4	L	CABLE ASS'Y, SMA(M) - SMA(M), 30 IN	

				
SYSTEM BLOCK DIAGRAM, 4006RZ-33, 50 IN RADOME				
PROD FAMILY LIT	EFF. DATE 20-Nov-07	SHT 1 OF 2	DRAWING NUMBER 126678-2	REV B

SINGLE LEVEL MFG BILL OF MATERIAL

FIND	QTY	PART NO	REV	DESCRIPTION	REFERENCE DESIGNATOR
50	3 EA	115492-1	C1	ADAPTER, N(F)-SMA(F), W/FLANGE	
60	1 EA	126144-1	A1	WAVEGUIDE, WR-75, 180 DEG E-BEND	
61	1 EA	117858	B	WAVEGUIDE FILTER, WR-75, KU-BAND, TX	
62	1 EA	120263	A	WAVEGUIDE, WR-75, 180 DEG H-BEND, M	
63	1 EA	126303-3	X3	WAVEGUIDE, WR-75, H-BEND WITH FLEX,	
64	1 EA	110172-12	F	WAVEGUIDE, WR-75, 90 DEG E-BEND, 2.25	
65	1 EA	125157-1	A	DIPLEXER, DPX75K-002, WR-75	
66	1 EA	123755-1	B2	WAVEGUIDE, WR-75, RIGID, W/FLEX	
67	1 EA	115477-6	C	WAVEGUIDE, WR-75, ROTARY JOINT, L-ST	
100	1 EA	125411-2	C	DAC-2202, DVB RCVR, 9 WIRE IF	
101	1 EA	116881-16	C	MUX RACK PANEL ASS'Y, RX SS, SF, TX (
102	1 EA	121628-4	M1	TERMINAL MOUNTING STRIP ASS'Y, ACU	
103	1 EA	117168-2	L1	MODEM ASS'Y, BASE, 3-CH. 75 OHM	
104	1 EA	117611-4	G	MODEM ASS'Y, BASE, 3 CH. -200, 50 OHM	
105	1 EA	116298-6	F4	HARNESS ASS'Y, ACU TO MUX/TERM TO	
106	1 EA	120643-25	A	CABLE ASS'Y, RS232, 9-WIRE, STRAIGHT,	
110	2 EA	121731-30	A	CABLE ASS'Y, LMR-400, N(M)-N(M), 30M L	(OPTION, SEE S/O)
111	1 EA	113303-10	S	CABLE ASS'Y, SMA 90 - SMA (M), 8 IN	
112	1 EA	114972-9	L	CABLE ASS'Y, SMA(M) - SMA(M), 6 IN	
113	2 EA	111115-6	B	CABLE ASS'Y, F(M)-F(M), 6 FT.	
114	1 EA	116700-6	F	CABLE ASS'Y, RG223, N(M)-F(M), 6 FT.	
115	1 EA	119479-10	B	CABLE ASS'Y, CAT5 JUMPER, 10 FT.	
116	1 EA	124095-36	E	CABLE ASS'Y, RJ45 SERIAL, IDIRECT	
120	1 EA	115492-1	C1	ADAPTER, N(F)-SMA(F), W/FLANGE	
121	1 EA	110567-19		ADAPTER, N(F)-N(F), STRAIGHT, FLANGE	

				
SYSTEM BLOCK DIAGRAM, 4006RZ-33, 50 IN RADOME				
PROD FAMILY LIT	EFF. DATE 20-Nov-07	SHT 2 OF 2	DRAWING NUMBER 126678-2	REV B

REVISION HISTORY

REV	ECO#	DATE	DESCRIPTION	BY
A	N/A	08/10/07	ADDED DASHES 2 & 3 TO TABLE, RELEASE TO PRODUCTION, WAS X2.	KRB
A1	5790	08/28/07	ITEM 63 WS 126303-2. ITEM 64 WS 110172-10. ITEM 66 WS 123755-1. ADDED ITEM 62.	KRB
B	5859	10/15/07	FIXED BALLOONS & LABELS; ITEM 24 WS 121966-4; ITEM 40 WS QTY 1; ITEM 60 WS 117429-1; ITEM 64 WS 110172-11; ITEM 101 WS 116881-18; ITEM 106 WS 120643-10; ITEM 113 WS 111115-3; ITEM 115 WS QTY 3; ITEM 120 WS QTY 3; ITEMS 26, 36-38 NEW	RJW

ABOVE DECKS EQUIPMENT
BELOW DECKS EQUIPMENT

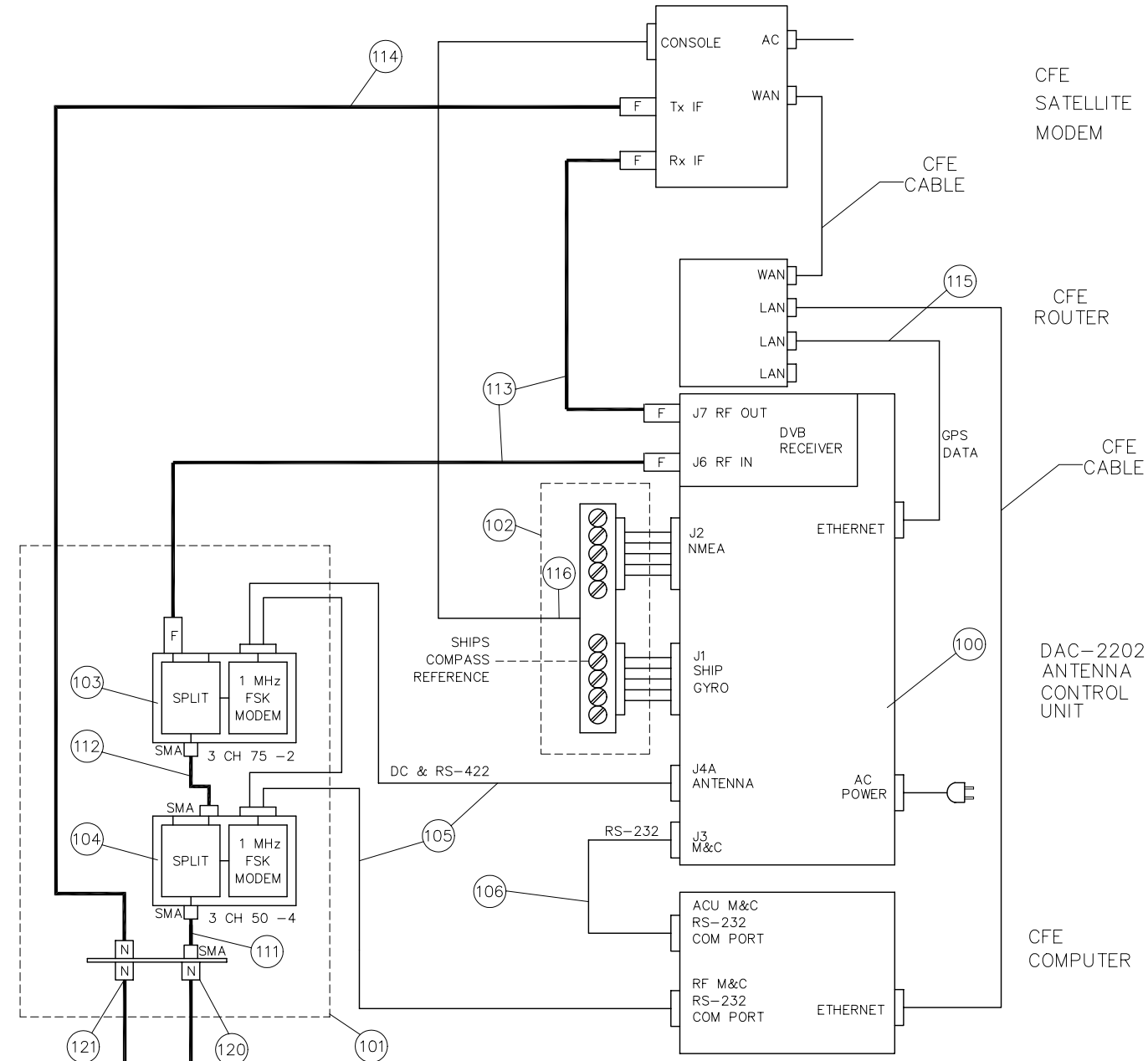
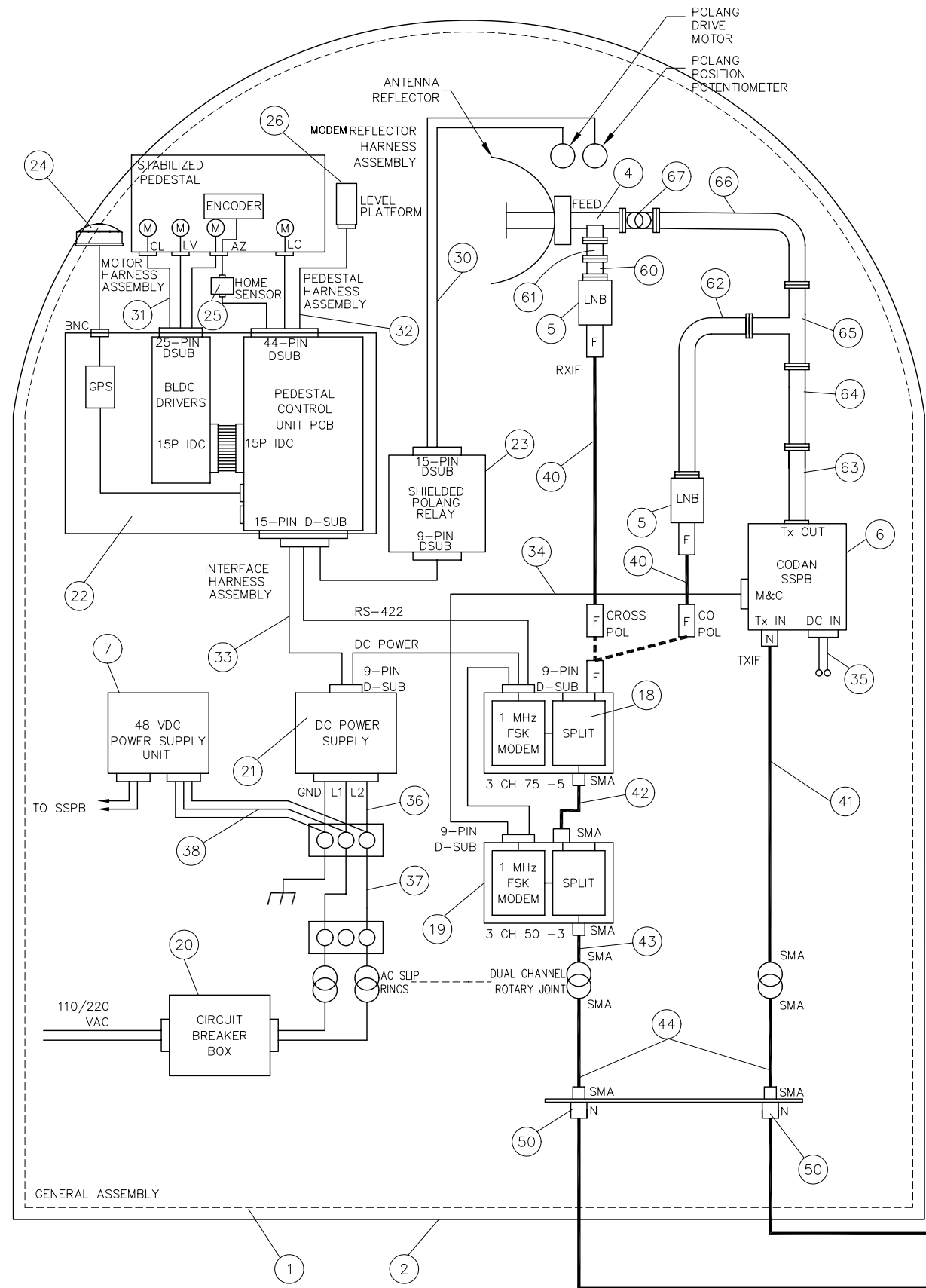

DASH #	DESCRIPTION	SYSTEM
-1	4006R-33, 60" RADOME	126675
-2	4006RZ-33, 50" RADOME	126951
-3	4006RZ-33, 60" RADOME	126938

REFERENCE DRAWINGS:
126677 ANTENNA SYSTEM SCHEMATIC
124348 ANTENNA PEDESTAL SCHEMATIC

TOLERANCES UNLESS OTHERWISE SPECIFIED		DRAWN BY: MSF		 4030 NELSON AVENUE CONCORD, CA 94520 Tel. 925-798-7979 Fax. 925-798-7986	
<48" = ± 1" <15' = ± 2" <100' = ± 4" >100' = ± 6" INTERPRET TOLERANCING PER ASME Y14.5M - 1994		DRAWN DATE: 05/24/07			
MATERIAL: N/A		APPROVED BY:		4006R-33/4006RZ-33	
FINISH: N/A		APPROVED DATE:		DRAWING NUMBER: 126678	
3rd ANGLE PROJECTION		FIRST USED: 4006R-33/4006RZ-33		SHEET NUMBER: 1 OF 1	

SINGLE LEVEL MFG BILL OF MATERIAL

FIND	QTY	PART NO	REV	DESCRIPTION	REFERENCE DESIGNATOR
1	1 EA	126944-2	A1	PEDESTAL ASS'Y, 4006RZ, 80 TO 110 LBS	
2	1 EA	126573-1	A2	ELECT EQU FRAME ASS'Y, 4006 KU-BAND,	
3	1 EA	126670-1	A1	AZ WEIGHT ASS'Y, 4006R	
5	1 EA	123511-1	A	ANTENNA ASS'Y, 4006	
6	1 EA	126679-1	B1	WAVEGUIDE ASS'Y, 4006RZ-33	
11	1 EA	114972-3	L	CABLE ASS'Y, SMA(M) - SMA(M), 84 IN	
12	1 EA	111079-8	G	CABLE ASS'Y, SMA(M)-N(M), 8 FT.	
13	1 EA	117164-60BLK	A4	CABLE ASS'Y, RG-179 COAX, F TO F, 60 IN	
14	1 EA	124288-36	D	CABLE ASS'Y, AC POWER, 36 IN	
15	1 EA	121485-3	F	HARNESS ASS'Y, REFLECTOR	
16	1 EA	125460-64	B	CABLE ASS'Y, PEDESTAL AC POWER 4006	
19	1 EA	119269-2	A1	GASKET, WR-75, (UG FULL)	
20	1 EA	119269-1	A1	GASKET, WR-75, (UG 1/2)	
22	1 EA	117585-7	A1	TERMINAL BLOCK, 4-POLE, 10-AWG	
23	0.5 EA	117585-7	A1	TERMINAL BLOCK, 4-POLE, 10-AWG	
40	1 EA	115998-2	J5	STRAP, RIGID WAVEGUIDE, KU-BAND	
41	1 EA	124393	B	BRACKET, RIGID WAVEGUIDE	
47	1 EA	121655-1	C1	LABELS INSTALLATION	
50	8 EA	114593-162		SCREW, SOCKET HD, 10-32 x 3/8, S.S.	
54	2 EA	118294-1	A3	HARDWARE KIT, WR-75 FLANGE, 6-32	
55	9 EA	114580-011		WASHER, FLAT, #10, S.S.	
56	8 EA	122076-333		WASHER, FLAT, #10, 18-8 SS, (.5 OD x 7/32	
57	4 EA	114583-011	A	NUT, HEX, 10-32, S.S.	
58	4 EA	114581-011		WASHER, LOCK, #10, S.S.	
59	4 EA	114593-164		SCREW, SOCKET HD, 10-32 x 1/2, S.S.	
62	1 EA	115697		TIE MOUNT	
63	1 EA	114593-149		SCREW, SOCKET HD, 8-32 x 7/8, S.S.	
64	1 EA	114593-162		SCREW, SOCKET HD, 10-32 x 3/8, S.S.	
65	3 EA	114593-168		SCREW, SOCKET HD, 10-32 x 7/8, S.S.	

				
GENERAL ASS'Y, 4006RZ-33 & 35, STD LNB				
PROD FAMILY 4006	EFF. DATE 20-Nov-07	SHT 1 OF 2	DRAWING NUMBER 126942-2	REV B

SINGLE LEVEL MFG BILL OF MATERIAL

FIND	QTY	PART NO	REV	DESCRIPTION	REFERENCE DESIGNATOR
66	1 EA	114580-009		WASHER, FLAT, #8, S.S.	

				
GENERAL ASS'Y, 4006RZ-33 & 35, STD LNB				
PROD FAMILY 4006	EFF. DATE 20-Nov-07	SHT 2 OF 2	DRAWING NUMBER 126942-2	REV B

REVISION HISTORY				
REV	ECO#	DATE	DESCRIPTION	BY
A2	5775	08/20/07	ITEM 50 WAS 114593-162. ITEM 55 WAS QTY 9. ITEM 58 WAS 114581-011. ITEM 63 WAS 114593-148.	KRB
A3	5790	08/28/07	ITEM 19 WAS QTY 2. UPDATED DRAWING VIEW WITH REVISED WAVEGUIDE. ADDED DASH TABLE.	KRB
B	5853	10/12/07	ADD NOTE 5. ADD ITEM 21, 51, 52 AND 53. ITEM 65 WS 114593-168, QTY WS 3. ITEM 13 QTY WS 1, ITEM 54 QTY WS 2, ITEM 57 QTY WS 4, ITEM 59 QTY WS 4 AND ITEM 66 QTY WS 1. REF DWG 121655-1 WS 124348.	SL

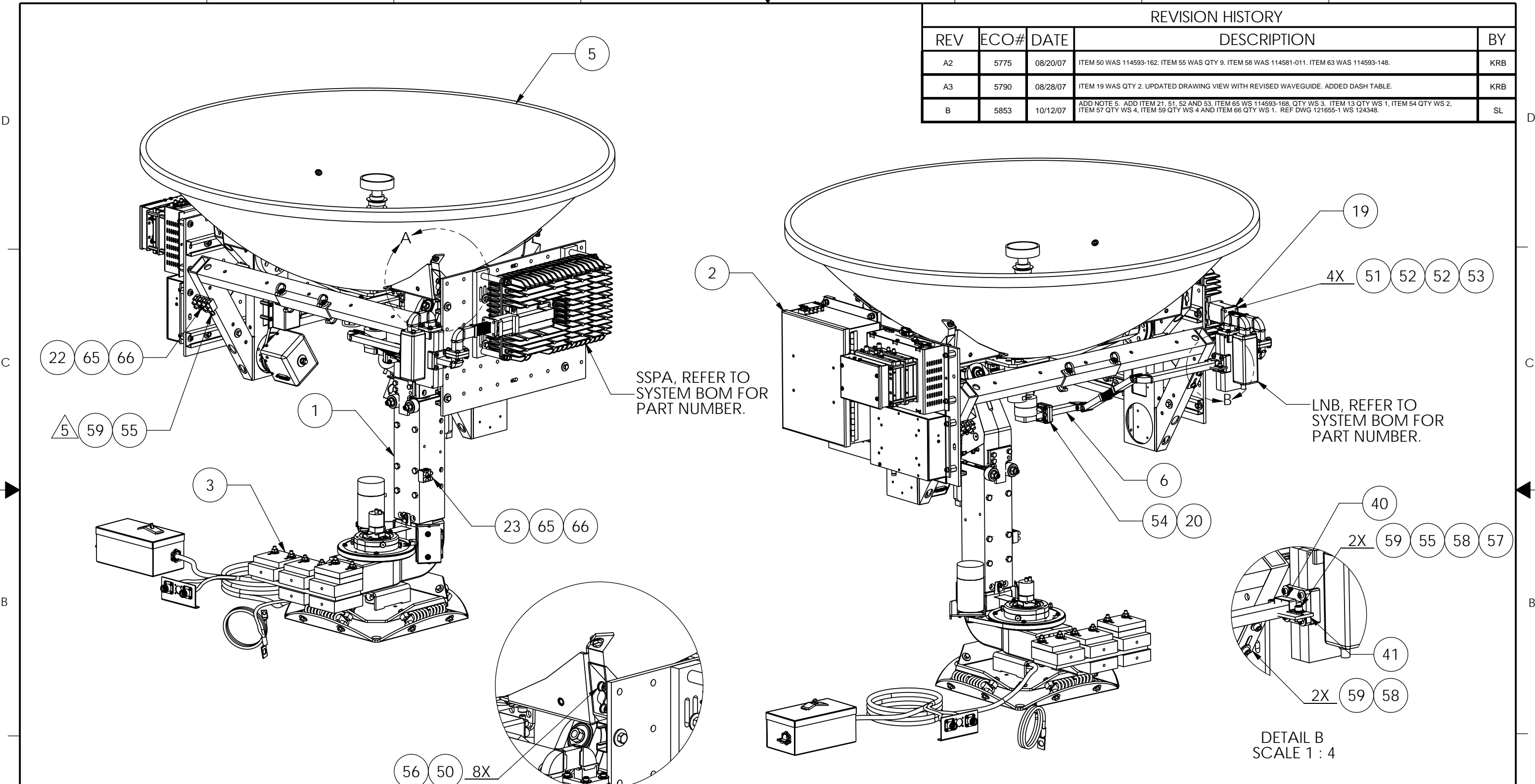

- NOTES: UNLESS OTHERWISE SPECIFIED**
1. APPLY ADHESIVE PER SEATEL SPEC. 121730.
 2. TORQUE THREADED FASTENERS PER SEATEL SPEC. 122305.
 3. TENSION ALL BELTS PER SEATEL SPEC. 122319.
 4. ROUTE ALL HARNESS AND CABLES ASSEMBLIES PER SEATEL SPEC. 121872.
- △ 5. GROUNDING POINT

REFERENCE DRAWINGS:

126678	SYSTEM BLOCK DIAGRAM
126677	ANTENNA SYSTEM SCHEMATIC
124348	PEDESTAL ANTENNA SCHEMATIC
121655-1	LABELS INSTALLATION

DASH #	DESCRIPTION
-1	POWERED LNB
-2	STANDARD LNB

UNLESS OTHERWISE SPECIFIED DIMENSIONS ARE IN INCHES. X.X = ±.050 X.XX = ±.020 X.XXX = ±.005 ANGLES: ±.5° INTERPRET TOLERANCING PER ASME Y14.5M - 1994		DRAWN BY: KRB		 4030 NELSON AVENUE CONCORD, CA 94520 Tel. 925-798-7979 Fax. 925-798-7986	
MATERIAL: N/A		DRAWN DATE: 08/07/07			
FINISH: N/A		APPROVED BY:		TITLE: GENERAL ASSEMBLY 4006RZ-33 /4006RZ-35	
3rd ANGLE PROJECTION		SIZE: B	SCALE: 1:8	DRAWING NUMBER: 126942	REV: B
FIRST USED: 4006RZ				SHEET NUMBER: 1 OF 1	

REV.	ECO#	DATE	DESCRIPTION	BY
A1	N/A	1-19-06	MODEM 3CH 200 -3 WS 3CH -1	MSF
A2	N/A	9-29-06	MODEM WAS 4006-23	MSF
A3	N/A	1-18-07	DWG UPDATED FOR 6006; NOTE 1 & 2 ADDED	MSF
A4	6609	4-20-07	NOTE 3 ADDED	MSF
A5	N/R	5-7-07	NOTE 1 WAS POWER SUPPLY ON 6006 ONLY	MSF

- NOTES:
- 1 POWER SUPPLY ON 6006 & 4006R ONLY.
 - 2 BRAKE NOT CURRENTLY AVAILABLE ON ALL XX06 MODELS.
 - 3 CONNECT DESIRED SIGNAL PATH TO MODEM.

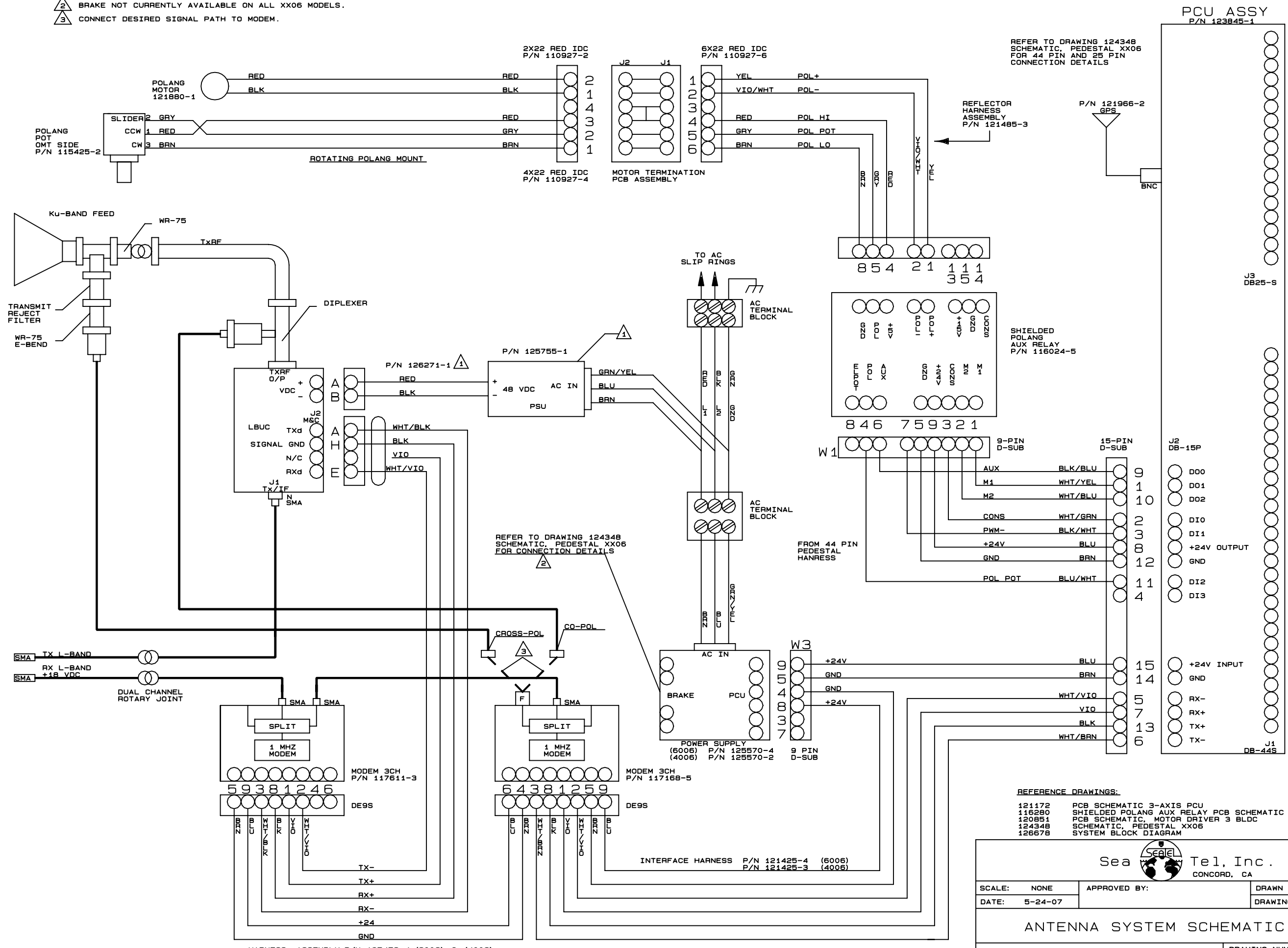

REFER TO DRAWING 124348 SCHEMATIC, PEDESTAL XX06 FOR 44 PIN AND 25 PIN CONNECTION DETAILS

REFER TO DRAWING 124348 SCHEMATIC, PEDESTAL XX06 FOR CONNECTION DETAILS

REFERENCE DRAWINGS:

121172	PCB SCHEMATIC 3-AXIS PCU
116280	SHIELDED POLANG AUX RELAY PCB SCHEMATIC
120851	PCB SCHEMATIC, MOTOR DRIVER 3 BLDC
124348	SCHEMATIC, PEDESTAL XX06
126678	SYSTEM BLOCK DIAGRAM

Sea  **Tel, Inc.**
CONCORD, CA

SCALE: NONE	APPROVED BY:	DRAWN BY MSF
DATE: 5-24-07		DRAWING SIZE: C

ANTENNA SYSTEM SCHEMATIC

MODEL: XX06-33	SHT 1 OF 1	DRAWING NUMBER	REV.
		126677	A5

HARNESS ASSEMBLY P/N 125476-4 (6006) & (4006)

SINGLE LEVEL MFG BILL OF MATERIAL

FIND	QTY	PART NO	REV	DESCRIPTION	REFERENCE DESIGNATOR
1	1 EA	122092	C	REFLECTOR MACHINING, 40 IN	
2	1 EA	123329-1	D	FEED ASS'Y, KU, CROSS-POLAR, W/ROTA	
3	2 EA	122034-1	B	CLIP, 40 IN. REFLECTOR	
4	2 EA	122034-2	C	CLIP, 40 IN. REFLECTOR	
5	1 EA	122066	B1	VERTEX FEED, 40 IN., 4003 MOD.	
50	8 EA	114588-829		SCREW, PAN HD, PHIL, 10-32 x 1/2, S.S.	
51	16 EA	122076-333		WASHER, FLAT, #10, 18-8 SS, (.5 OD x 7/32	
53	8 EA	114583-011	A	NUT, HEX, 10-32, S.S.	
54	4 EA	114593-106		SCREW, SOCKET HD, 4-40 x 1/2, S.S.	
55	4 EA	114590-110		SCREW, SOCKET SET-CUP, 4-40 x 1/2, S.S	
56	4 EA	114583-005		NUT, HEX, 4-40, S.S.	
57	4 EA	114580-005		WASHER, FLAT, #4, S.S.	
59	4 EA	119961-007		NUT, HEX, SMALL PATTERN, 6-32, S.S.	
60	4 EA	114580-008		WASHER, FLAT, #6, SMALL PATTERN, S.S.	
61	4 EA	114590-148		SCREW, SOCKET SET-CUP, 6-32 x 1/2, S.S	

				
ANTENNA ASS'Y, 4006				
PROD FAMILY COMMON	EFF. DATE 02-Feb-07	SHT 1 OF 1	DRAWING NUMBER 123511-1	REV A

NOTES: UNLESS OTHERWISE SPECIFIED
 1. APPLY ADHESIVE PER SEATEL SPEC. 121730.
 2. TORQUE THREADED FASTENERS PER SEATEL SPEC. 122305.

REVISION HISTORY				
REV	ECO#	DATE	DESCRIPTION	BY
A	N/A	10-28-05	PRODUCTION RELEASE FROM X4 TO A.	SL

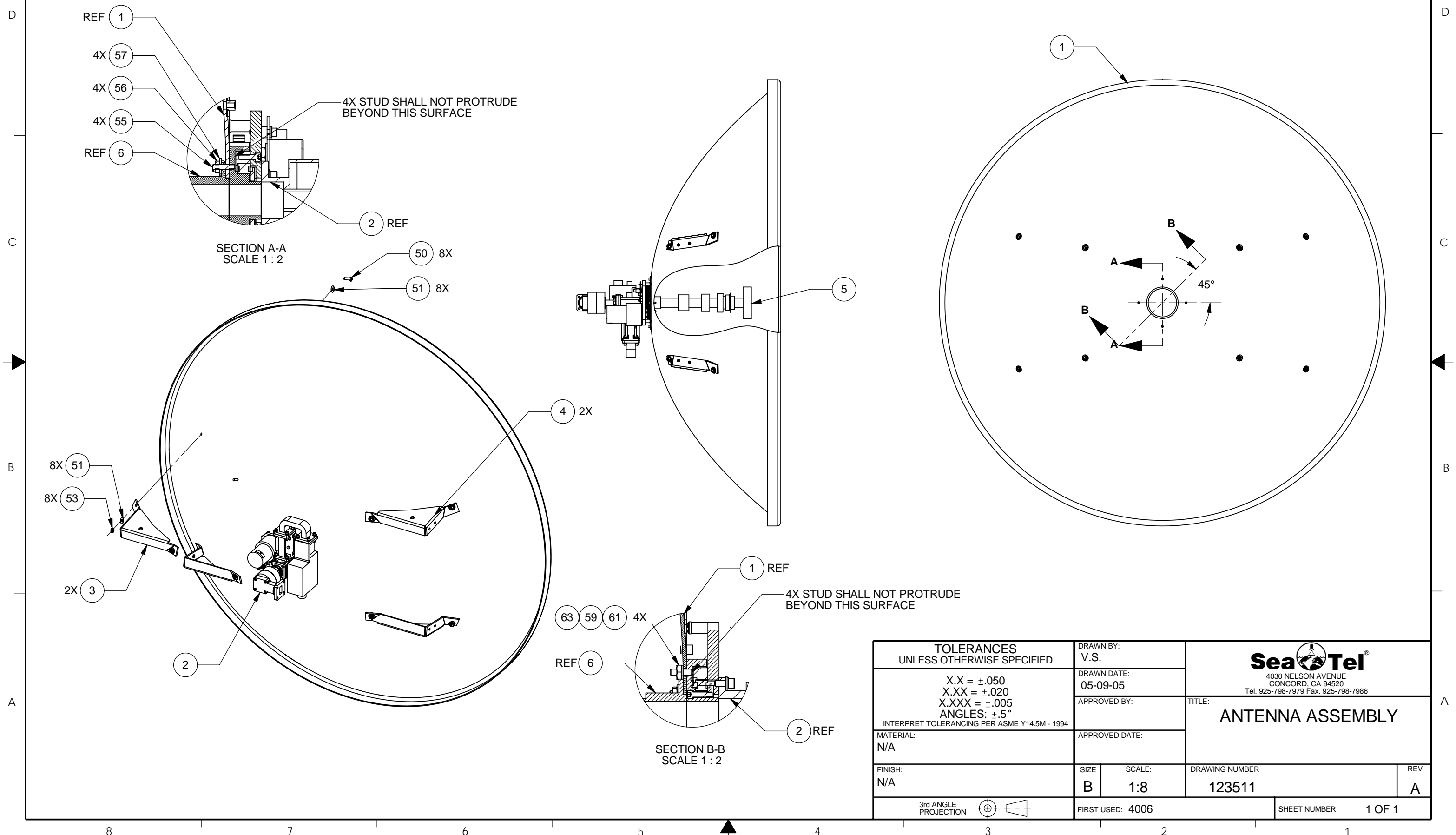

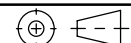
TOLERANCES UNLESS OTHERWISE SPECIFIED		DRAWN BY: V.S.		 4030 NELSON AVENUE CONCORD, CA 94520 Tel. 925-798-7979 Fax. 925-798-7986	
X.X = ±.050 X.XX = ±.020 X.XXX = ±.005 ANGLES: ±.5° <small>INTERPRET TOLERANCING PER ASME Y14.5M - 1994</small>		DRAWN DATE: 05-09-05			
MATERIAL: N/A		APPROVED BY:		TITLE: ANTENNA ASSEMBLY	
FINISH: N/A		APPROVED DATE:		DRAWING NUMBER: 123511	
3rd ANGLE PROJECTION 		SIZE: B	SCALE: 1:8	FIRST USED: 4006	REV: A
				SHEET NUMBER: 1 OF 1	

SINGLE LEVEL MFG BILL OF MATERIAL

FIND	QTY	PART NO	REV	DESCRIPTION	REFERENCE DESIGNATOR
1	1 EA	125268-1	A1	RADOME TOP FAB, 50 IN, WHITE	
2	1 EA	127030-1	B	RADOME BASE ASS'Y, 50 IN, WHITE, DUR	
4	1 EA	118576	B1	MOUNTING KIT, PEDESTAL	
5	4 EA	119801-012	B	CABLE TIE, NYLON, 4 IN, NATURAL	
6	7 EA	119801-019	B	CABLE TIE, NYLON, 7.5 IN, NATURAL	
7	1 EA	111679-5	0	CABLE CLAMP, NYLON, 3/8 DIA, #8 MTG H	
8	1 EA	111679-7	0	CABLE CLAMP, NYLON, 1/2 DIA, #8 MTG H	
9	1 EA	111679-25	0	CABLE CLAMP, NYLON, 3/4 DIA, #10 MTG	
10	0.1 OZ	116702		ADHESIVE/SEALANT, E6000	NOT SHOWN
15	1 EA	109783-2		WRENCH, L	
16	1 EA	123549	D4	KIT, RADOME HARDWARE MOUNTING	
50	2 EA	114588-148		SCREW, PAN HD, PHIL, 6-32 x 1/2, S.S.	
51	4 EA	114580-007		WASHER, FLAT, #6, S.S.	
52	2 EA	114583-007		NUT, HEX, 6-32, S.S.	
53	3 EA	114588-196		SCREW, PAN HD, PHIL, 8-32 x 5/8, S.S.	
54	6 EA	114580-009		WASHER, FLAT, #8, S.S.	
55	3 EA	114583-009		NUT, HEX, 8-32, S.S.	
60	3 EA	114588-832		SCREW, PAN HD, PHIL, 10-32 x 7/8, S.S.	
61	6 EA	114580-011		WASHER, FLAT, #10, S.S.	
62	3 EA	114583-011	A	NUT, HEX, 10-32, S.S.	
63	3 EA	121226-7014		SPACER, #10 X .38 OD X .13, ALUM, ALODI	

				
RADOME ASS'Y, 4003/4006 GA INSTALL, 50 IN WHITE				
PROD FAMILY COMMON	EFF. DATE 20-Nov-07	SHT 1 OF 1	DRAWING NUMBER 125622-1	REV C

REVISION HISTORY				
REV	ECO#	DATE	DESCRIPTION	BY
B	5798	09-06-07	IN BOM ITEM 2 WS 125585-1,-2,-3,-4 & -6	HT
B1	5872	10-12-07	DELETED ITEM 3 (SHT 2)	LAE
C	5849	10-4-07	CABLE REROUTED TO AVOID SHIPPING STRAPS; DELETED ITEMS 56-58	RJW

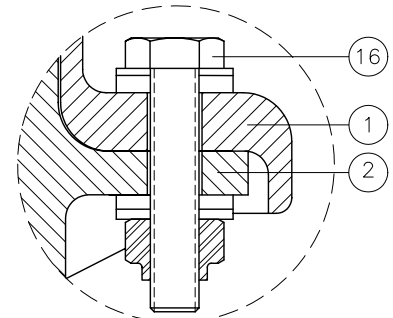
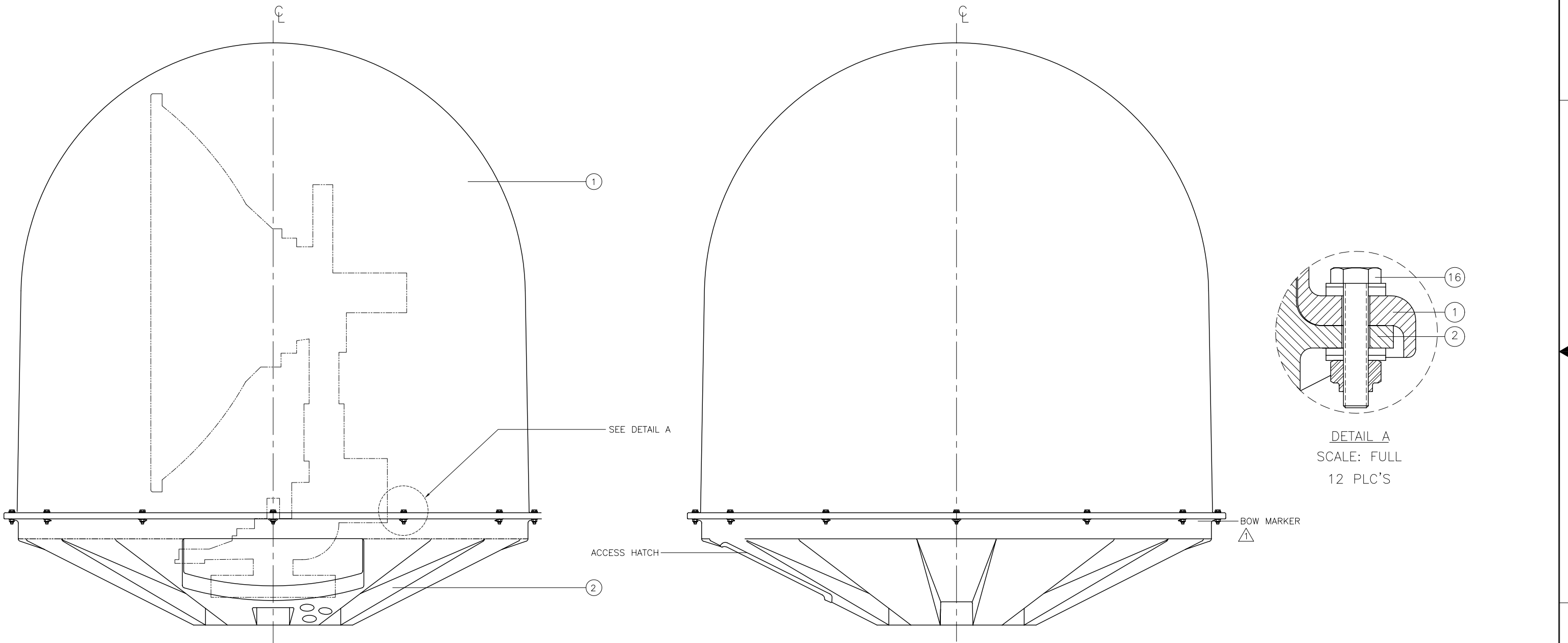

DETAIL A
SCALE: FULL
12 PLC'S

DASH	DESCRIPTION
-1	WHITE
-2	FRENCH NAVY GREY
-3	IRISH NAVY GREY
-4	DANISH NAVY GREY
-5	GREY RAL 7001

- NOTES, UNLESS OTHERWISE SPECIFIED:
- 1 BOW MARKER LOCATION DIRECTLY OPPOSITE FROM ACCESS HATCH.
 - 2. APPLY ADHESIVE PER SEA TEL SPEC. 121730.
 - 3. BAG AND ATTACH RADOME MOUNTING KIT, ITEM 16, TO INSIDE OF RADOME.
 - 4 APPLY E6000 TO ALL DRILLED HOLES PRIOR TO INSTALLING HARDWARE.

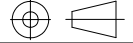
UNLESS OTHERWISE SPECIFIED DIMENSIONS ARE IN INCHES. X.X = ±.050 X.XX = ±.020 X.XXX = ±.005 ANGLES: ±.5° INTERPRET TOLERANCING PER ASME Y14.5M - 1994	DRAWN BY: SL		 4030 NELSON AVENUE CONCORD, CA 94520 Tel. 925-798-7979 Fax. 925-798-7986	
	DRAWN DATE: 8-9-06			
MATERIAL: N/A	APPROVED BY:		TITLE: RADOME ASSY, 4003/4006 GA INSTALL, 50IN	
FINISH: N/A	APPROVED DATE:	SIZE: B	SCALE: 1:10	DRAWING NUMBER: 125622
3rd ANGLE PROJECTION 		FIRST USED: 4003	SHEET NUMBER: 1 OF 2	

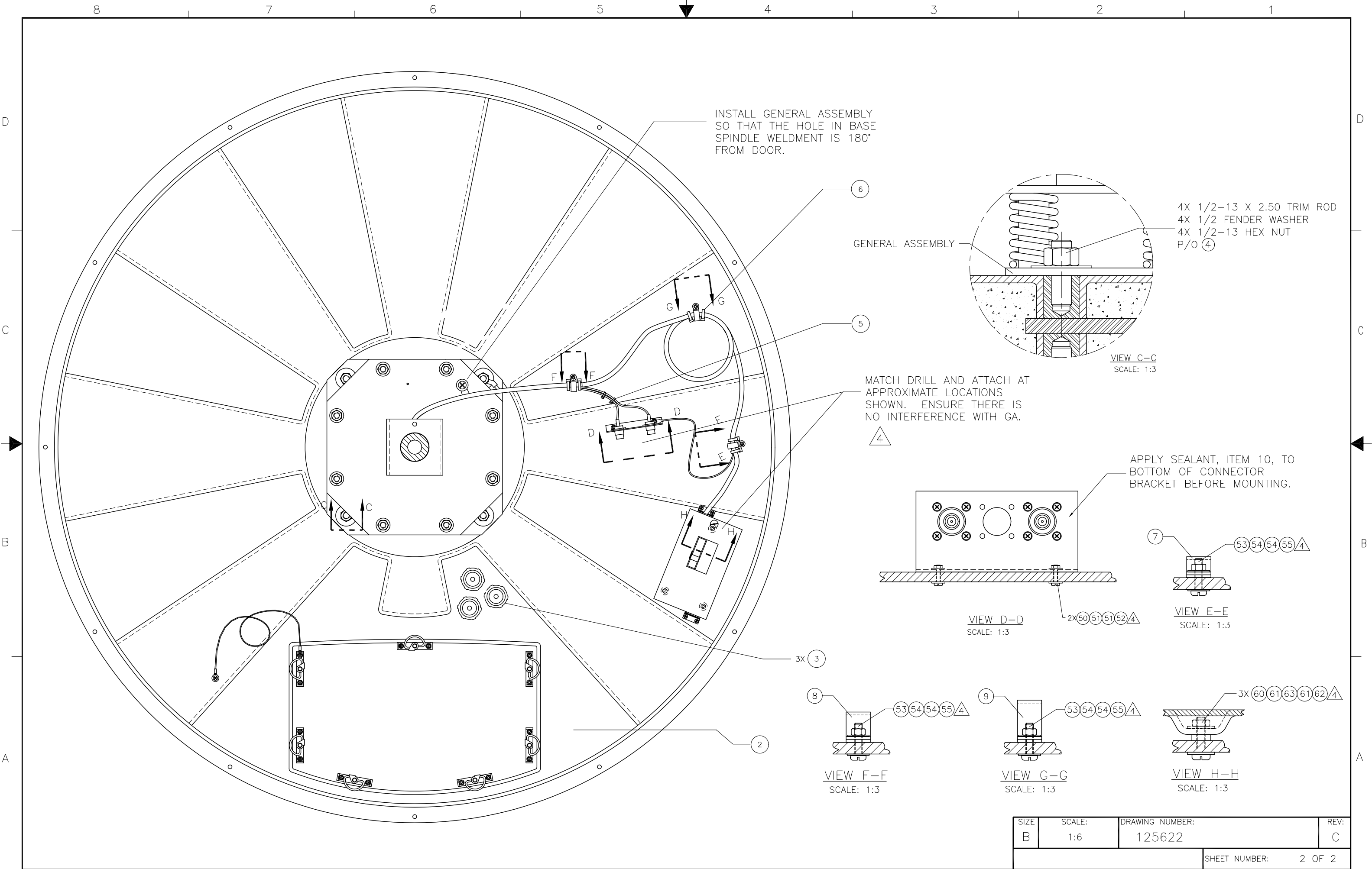

SIZE	SCALE:	DRAWING NUMBER:	REV:
B	1:6	125622	C
SHEET NUMBER:			2 OF 2

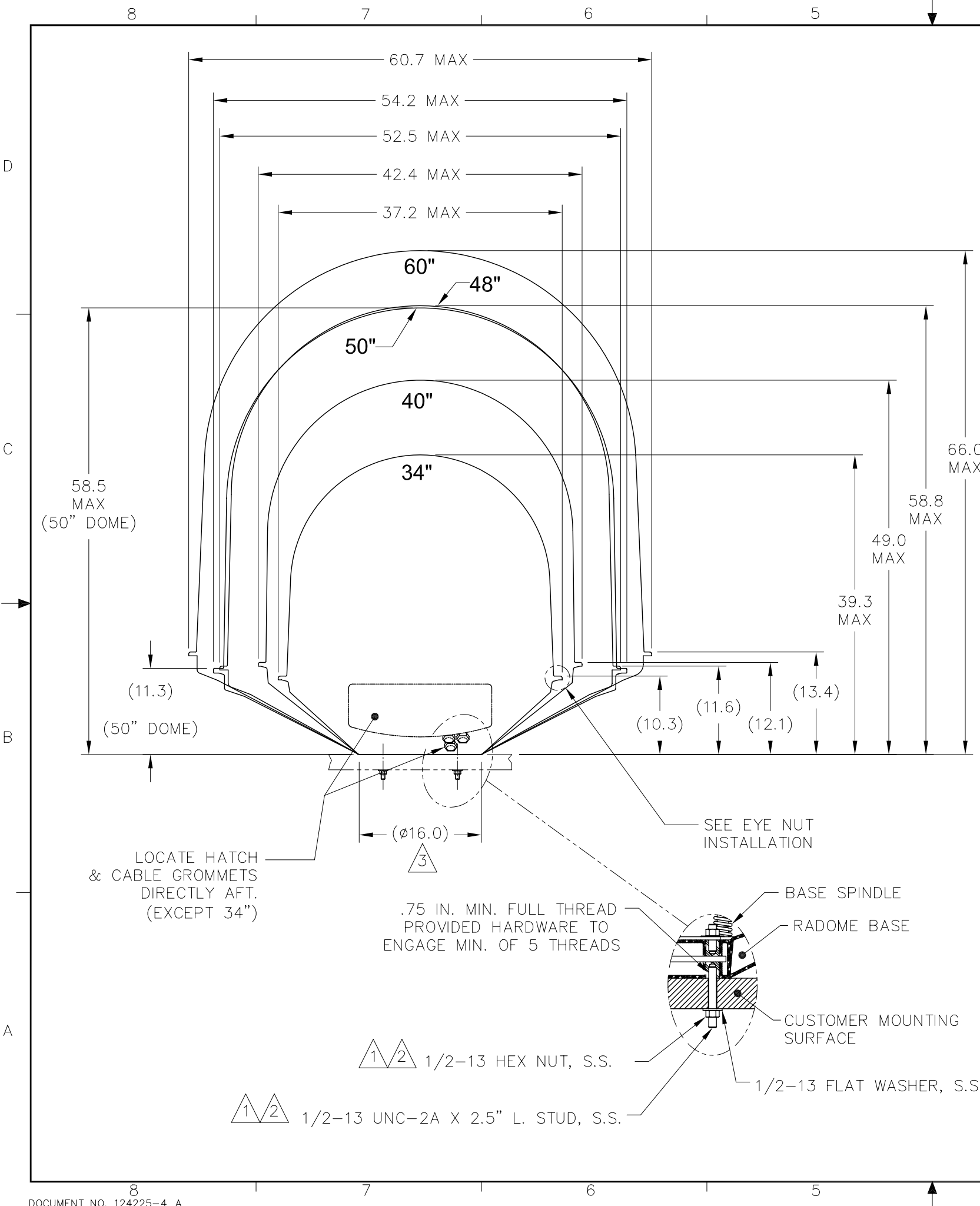

REVISION HISTORY				
REV	ECO#	DATE	DESCRIPTION	BY
B1	N/A	4-25-05	CHANGED MOUNTING KIT P/N FROM 118569 TO 123549 ON NOTES 2 & 3.	AEF
B2	N/A	6-1-05	DIMENSIONS VERIFIED AND CORRECTED TO CURRENT BUILD.	L.R.
B3	N/A	11/18/05	DETAIL FOR EYE NUT INSTALL. REDRAWN TO SHOW MORE REDOME REFERENCE OUTLINE.	AEF
B4	N/A	9-8-06	ADD 50 INCH READOME. NOTE "LOCATE HATCH & CABLE GROMMETS DIRCTLY AFT	SL
"	"	"	(EXCEPT 34") " WS "LOCATE HATCH (48"& 60" ONLY) & CABLE GROMMETS DIRECTLY AFT."	SL

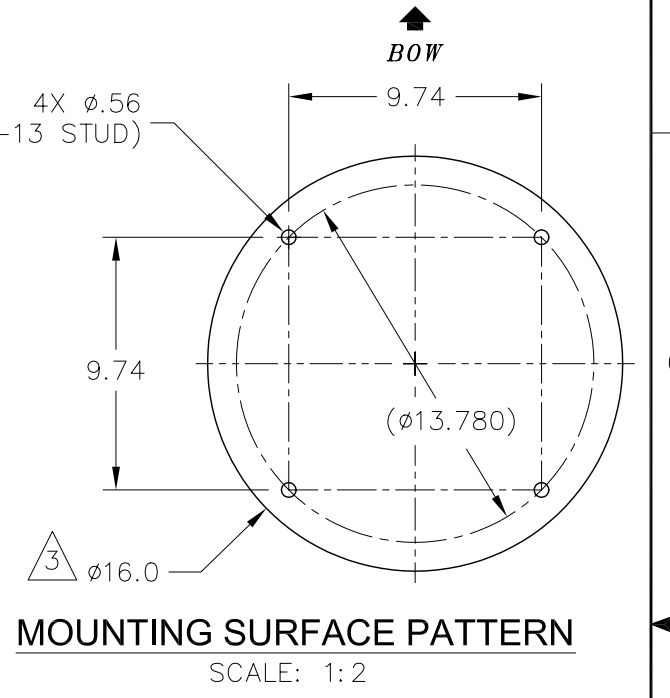
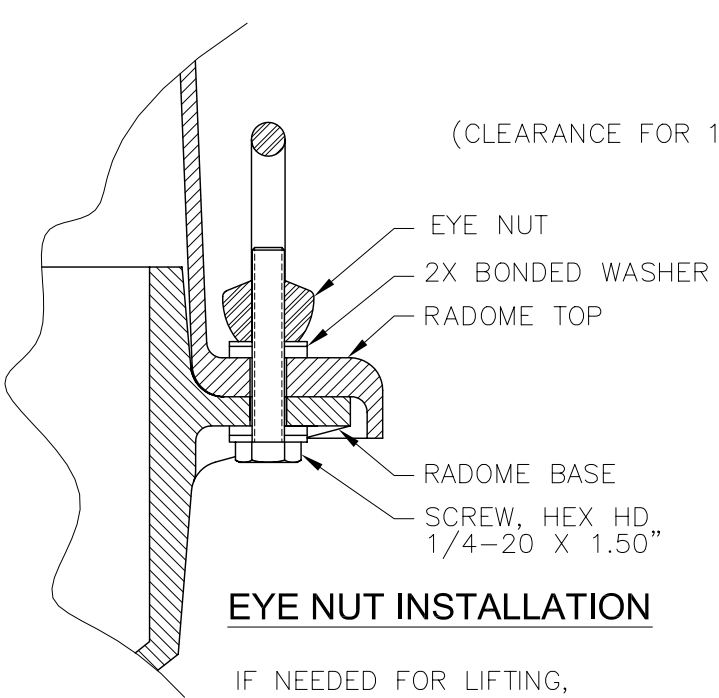

EYE NUT INSTALLATION

IF NEEDED FOR LIFTING, INSTALL 4X EYE NUTS. (PART OF RADOME KIT P/N: 123549) EQUALLY SPACED.

NOTES: UNLESS OTHERWISE SPECIFIED

1 INDICATED ITEMS ARE PART OF MOUNTING KIT P/N: 123549

2 APPLY ADHESIVE PER SEATEL SPEC. 121730. LOCTITE 271 (RED) PROVIDED WITH MOUNTING KIT, P/N 123549

3 MINIMUM DIAMETER OF MAST MOUNTNG PLATE EQUAL TO RADOME BASE DIAMETER.

REFERENCE DRAWINGS

122356 RADOME ASS'Y, 60"
 122353 RADOME ASS'Y, 48"
 122350 RADOME ASS'Y, 40"
 122326 RADOME ASS'Y, 34"

TOLERANCES UNLESS OTHERWISE SPECIFIED X.X = ±.050 X.XX = ±.020 X.XXX = ±.005 ANGLES: ±.5° INTERPRET TOLERANCING PER ASME Y14.5M - 1994	DRAWN BY: P. McCANN	4030 NELSON AVENUE CONCORD, CA 94520 Tel. 925-798-7979 Fax. 925-798-7986
	DRAWN DATE: 3-4-04	
MATERIAL: --	APPROVED BY:	DRAWING NUMBER: 122663
FINISH: --	SIZE: B SCALE: 1/15	REV: B4
3rd ANGLE PROJECTION	FIRST USED: --	SHEET NUMBER: 1 of 1

SINGLE LEVEL MFG BILL OF MATERIAL

FIND	QTY	PART NO	REV	DESCRIPTION	REFERENCE DESIGNATOR
1	1 EA	125096-1	A	BELT KIT, 4006	
2	1 EA	123845-1	A	PCU ENCLOSURE ASS'Y, 4006	
3	1 EA	116024-5	J2	SHIELDED POLANG RELAY ASS'Y	
4	1 EA	122937-1	D2	LEVEL CAGE ASS'Y, BOTTOM EXIT, 90 DE	
5	2 EA	116139-3	J3	SIZE 23 BRUSHLESS MOTOR	
6	2 EA	114079-2	0	PULLEY, 1/5P 10T, 2FLG	
7	2 EA	114590-142		SCREW, SOCKET SET-CUP, 6-32 x 1/8, S.S.	
8	1 EA	116059-1	F2	MOTOR, LEVEL CAGE W/WIRING	
9	1 EA	113270	C	SPROCKET, TIMING	
10	2 EA	119985		SCREW, SET, 6-40 x 3/16 IN, S.S.	
11	1 EA	121951	D1	MOTOR, SZ 23 DOUBLE STACK/W ENCOD	
12	1 EA	108944-3	K1	PULLEY, TIMING, 10T	
13	1 EA	114590-188		SCREW, SOCKET SET-CUP, 8-32 x 1/8, S.S.	
14	1 EA	121880-1	A	MOTOR ASS'Y, POLANG, (PRI-FOCUS)	
15	1 EA	115425-2	J1	POT ASS'Y (ELEX.), POLANG	
16	2 EA	117139	C	GEAR, MOD., SPUR	
17	2 EA	114590-824		SCREW, SOCKET SET-CUP, 10-32 x 3/16, S	

				
SPARE PARTS KIT, 4006 STANDARD				
PROD FAMILY COMMON	EFF. DATE 17-Oct-06	SHT 1 OF 1	DRAWING NUMBER 125093-1	REV A

SINGLE LEVEL MFG BILL OF MATERIAL

FIND	QTY	PART NO	REV	DESCRIPTION	REFERENCE DESIGNATOR
1	1 EA	125093-1	A	SPARE PARTS KIT, 4006 STANDARD	
2	1 EA	117168-1	H	MODEM ASS'Y, PEDESTAL, 3-CH. 75 OHM	
3	1 EA	117168-2	H	MODEM ASS'Y, BASE, 3-CH. 75 OHM	
4	1 EA	122555-90	A1	POWER SUPPLY, IDEC, PS5R-SE24	
5	1 EA	114789-810		TRANSPORT CONTAINER	

				
SPARE PARTS KIT, 4006 PREMIUM				
PROD FAMILY COMMON	EFF. DATE 17-Oct-06	SHT 1 OF 1	DRAWING NUMBER 125094-1	REV A

SINGLE LEVEL MFG BILL OF MATERIAL

FIND	QTY	PART NO	REV	DESCRIPTION	REFERENCE DESIGNATOR
1	1 EA	125094-1	A	SPARE PARTS KIT, 4006 PREMIUM	
2	1 EA	122188-1	A1	LNB, 11.70 TO 12.20 GHz, PLL, +/- 3 ppm, T	
3	1 EA	122188-2	A1	LNB, 12.25 TO 12.75 GHz, PLL, +/- 3 ppm, T	
4	1 EA	122188-3	A1	LNB, 10.95 TO 11.70 GHz, PLL, +/- 3 ppm, T	
5	1 EA	124068-1	A	ROTARY JOINT, COAXIAL, DUAL CHANNEL	
6	1 EA	121966-2	B	GPS ANTENNA, RETERMINATED, 21.0 L	

				
SPARE PARTS KIT, 4006 MASTER				
PROD FAMILY COMMON	EFF. DATE 17-Oct-06	SHT 1 OF 1	DRAWING NUMBER 125095-1	REV A

REVISION HISTORY

REV	ECO#	DATE	DESCRIPTION	BY
B	5319	5-29-06	NOTE 2 ADDED	MSF
B1	N/A	1-19-07	NOTE 2 UPDATED; NOTE 3 ADDED	MSF

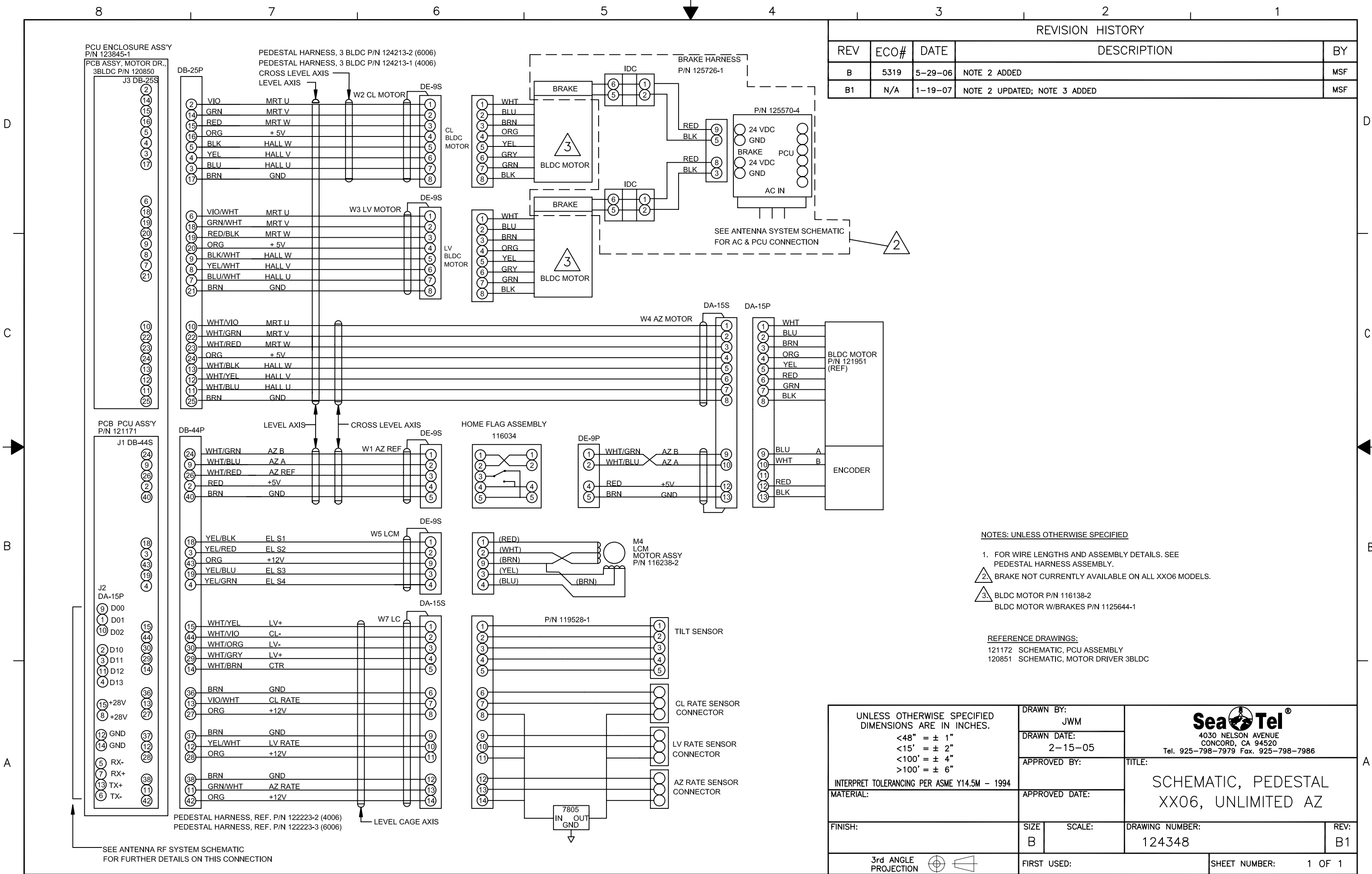

NOTES: UNLESS OTHERWISE SPECIFIED

- FOR WIRE LENGTHS AND ASSEMBLY DETAILS. SEE PEDESTAL HARNESS ASSEMBLY.
- BRAKE NOT CURRENTLY AVAILABLE ON ALL XX06 MODELS.
- BLDC MOTOR P/N 116138-2
BLDC MOTOR W/BRAKES P/N 1125644-1

REFERENCE DRAWINGS:
121172 SCHEMATIC, PCU ASSEMBLY
120851 SCHEMATIC, MOTOR DRIVER 3BLDC

UNLESS OTHERWISE SPECIFIED DIMENSIONS ARE IN INCHES. <48" = ± 1" <15' = ± 2" <100' = ± 4" >100' = ± 6"	DRAWN BY: JWM		 4030 NELSON AVENUE CONCORD, CA 94520 Tel. 925-798-7979 Fax. 925-798-7986	
	DRAWN DATE: 2-15-05			
INTERPRET TOLERANCING PER ASME Y14.5M - 1994	APPROVED BY:		TITLE: SCHEMATIC, PEDESTAL XX06, UNLIMITED AZ	
MATERIAL:	APPROVED DATE:		DRAWING NUMBER: 124348	
FINISH:	SIZE: B	SCALE:	DRAWING NUMBER: 124348	REV: B1
3rd ANGLE PROJECTION		FIRST USED:	SHEET NUMBER: 1 OF 1	

SINGLE LEVEL MFG BILL OF MATERIAL

FIND	QTY	PART NO	REV	DESCRIPTION	REFERENCE DESIGNATOR
1	1 EA	112657	D	MACHINING, TERMINAL MOUNTING STRIP	
2	1 EA	116529	C	PCB ASS'Y, TERMINAL MOUNTING, 25 PIN	
3	1 EA	112936	D	CABLE ASS'Y, D-SUB, 25 PIN	
4	1 EA	116527	A	PCB ASS'Y, TERMINAL MOUNTING, 9 PIN	
5	1 EA	116669-36	B	CABLE ASS'Y, D-SUB, 9-PIN, 36 IN.	
7	4 EA	121228-3072		STANDOFF, HEX, F/F, 6-32 X .25 OD X .50,	
9	6 EA	114588-146		SCREW, PAN HD, PHIL, 6-32 x 3/8, S.S.	
10	2 EA	114580-007		WASHER, FLAT, #6, S.S.	
11	10 EA	119952-007	A1	WASHER, STAR, INTERNAL TOOTH, #6, S.	
12	2 EA	114583-007		NUT, HEX, 6-32, S.S.	
13	1 EA	121534		DEVICE SERVER, ETHERNET, LANTRONIX	
14	1 EA	121624	C	CABLE ASS'Y, LANTRONICS TO TERM. ST	
19	4 EA	114588-144		SCREW, PAN HD, PHIL, 6-32 x 1/4, S.S.	
21	2 EA	114588-106		SCREW, PAN HD, PHIL, 4-40 x 1/4, S.S.	
22	2 EA	119952-005	A1	WASHER, STAR, INTERNAL TOOTH, #4, S.	

				
TERMINAL MOUNTING STRIP ASS'Y, ACU				
PROD FAMILY ELEC	EFF. DATE 05-Jun-07	SHT 1 OF 1	DRAWING NUMBER 121628	REV L

NOTES (UNLESS OTHERWISE SPECIFIED):

1. APPLY ADHESIVE PER SEATEL SPEC. 121730

△2 N/A IN THIS SHEET

△3 INSERT TERMINALS ON CABLE (ITEM 14) INTO CONNECTORS ON ITEMS 4 WITH FLAT SIDE OF CRIMP PINS FACING DOWN, AND TIGHTEN CONNECTOR FIRMLY.

△4 N/A IN THIS SHEET

△5 N/A IN THIS SHEET

REVISION HISTORY				
REV	ECO#	DATE	DESCRIPTION	BY
H	4776	4-1-05	DASH 2: ADD ITEM 22, UPDATE NOTE 2. ADD NOTE 4.	SCC
J	4891	6-1-05	ADD DASH 3. REORDERED SHEETS. UPDATED HARDWARE.	L.R.
K	4928	7-7-05	NON DASH ITEM 14 WAS 123071. -2 & -3 ADD ITEM 28 (121899-18), ADD NOTE 5.	L.R.
K1	N/A	12-9-05	CHG'D ITEM 7 FROM 111672-36 TO 121228-3072.	RJW
K2	5181	6-8-06	ADDED SHT. 4, DASH 4 & P/N 116685 TO REF. DWGS.	MSF
L	5648	6-4-07	DASH 4 ITEM 14 WAS 125520-36; DASH 2 ITEM 14 WAS 124095-36; DASH TABLE UPDATED	MSF

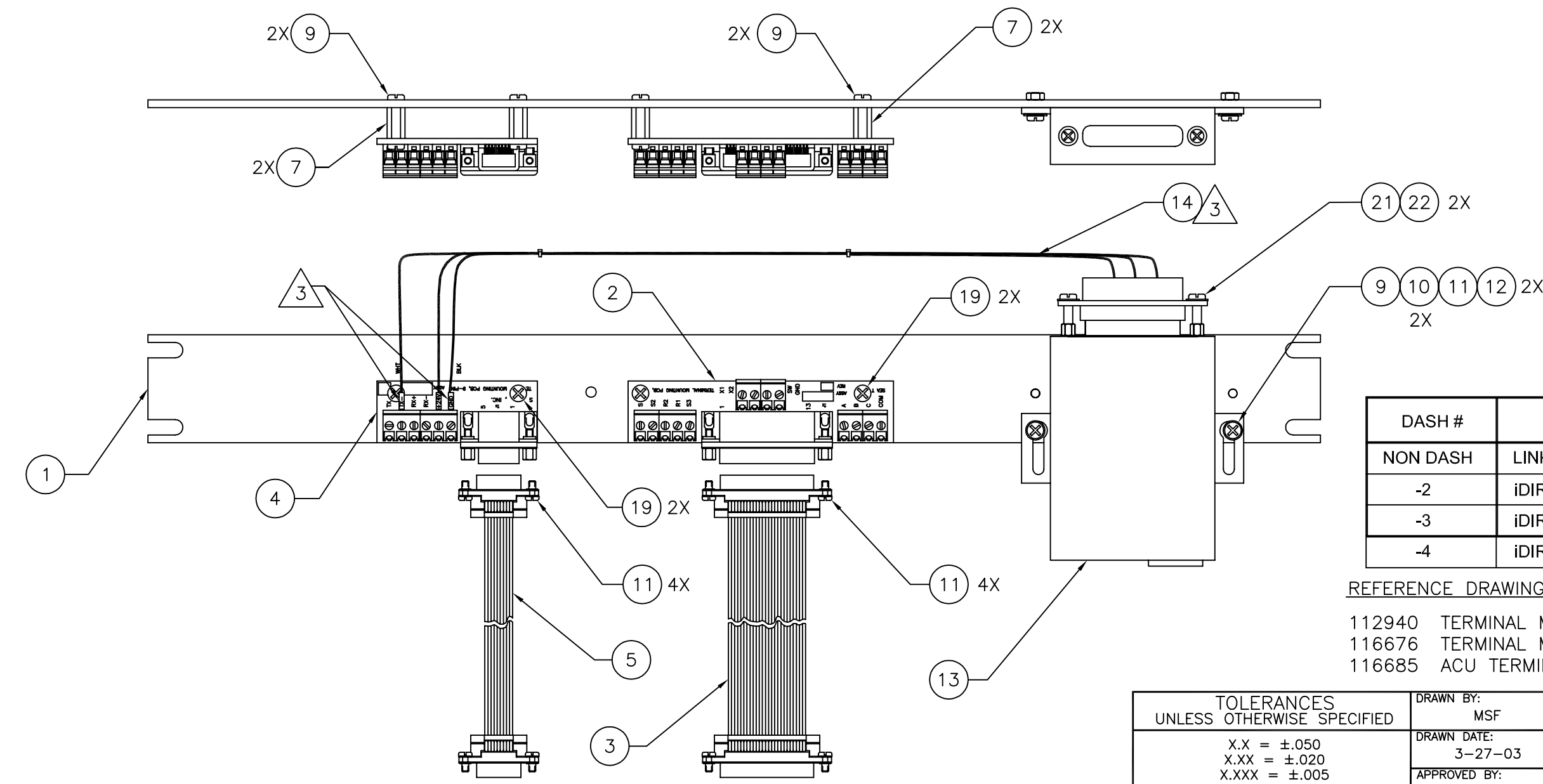

DASH #	SYSTEM	SHT. #
NON DASH	LINKSTAR-EDGE ACCESS	SHT. 1
-2	iDIRECT/VOIP	SHT. 2
-3	iDIRECT/LANTronixs/VOIP	SHT. 3
-4	iDIRECT/INFOSAT	SHT. 4

REFERENCE DRAWINGS:

- 112940 TERMINAL MOUNTING STRIP ASSEMBLY
- 116676 TERMINAL MOUNTING STRIP ASSEMBLY
- 116685 ACU TERMINAL MOUNTING STRIP SCHEMATIC

TOLERANCES UNLESS OTHERWISE SPECIFIED X.X = ±.050 X.XX = ±.020 X.XXX = ±.005 ANGLES: ±.5° INTERPRET TOLERANCING PER ASME Y14.5M - 1994	DRAWN BY: MSF	4030 NELSON AVENUE CONCORD, CA 94520 Tel. 925-798-7979 Fax. 925-798-7986	
	DRAWN DATE: 3-27-03		
MATERIAL: --	APPROVED BY: _____		TITLE: TERMINAL MOUNTING STRIP ASSEMBLY
FINISH: --	APPROVED DATE: _____		DRAWING NUMBER: 121628
3rd ANGLE PROJECTION	SIZE: B SCALE: 1/2	DRAWING NUMBER: 121628	
FIRST USED: 4003	SHEET NUMBER: 1 of 4	REV: L	

NOTES (UNLESS OTHERWISE SPECIFIED):

1. APPLY ADHESIVE PER SEATEL SPEC. 121730

2. INSERT SIL-PAD, ITEM 22, BETWEEN REGULATOR & TERMINAL MOUNTING STRIP. ROTATE REGULATOR ASS'Y, ITEM 17, TO PROTECT LEADS FROM BREAKING.

3. INSERT TERMINALS ON CABLE (ITEM 14) INTO CONNECTORS ON ITEMS 4 WITH FLAT SIDE OF CRIMP PINS FACING DOWN, AND TIGHTEN CONNECTOR FIRMLY.

4. SECURE RJ45 SERIAL CABLE, ITEM 14, WITH TIE WRAP TO STANDOFF, ITEM 7.

5. -2 AND -3 ONLY, CRIMP END OF YELLOW WIRE (ITEM 17) AND ORANGE WIRE (ITEM 14) WITH PIN TERMINAL ITEM 28.

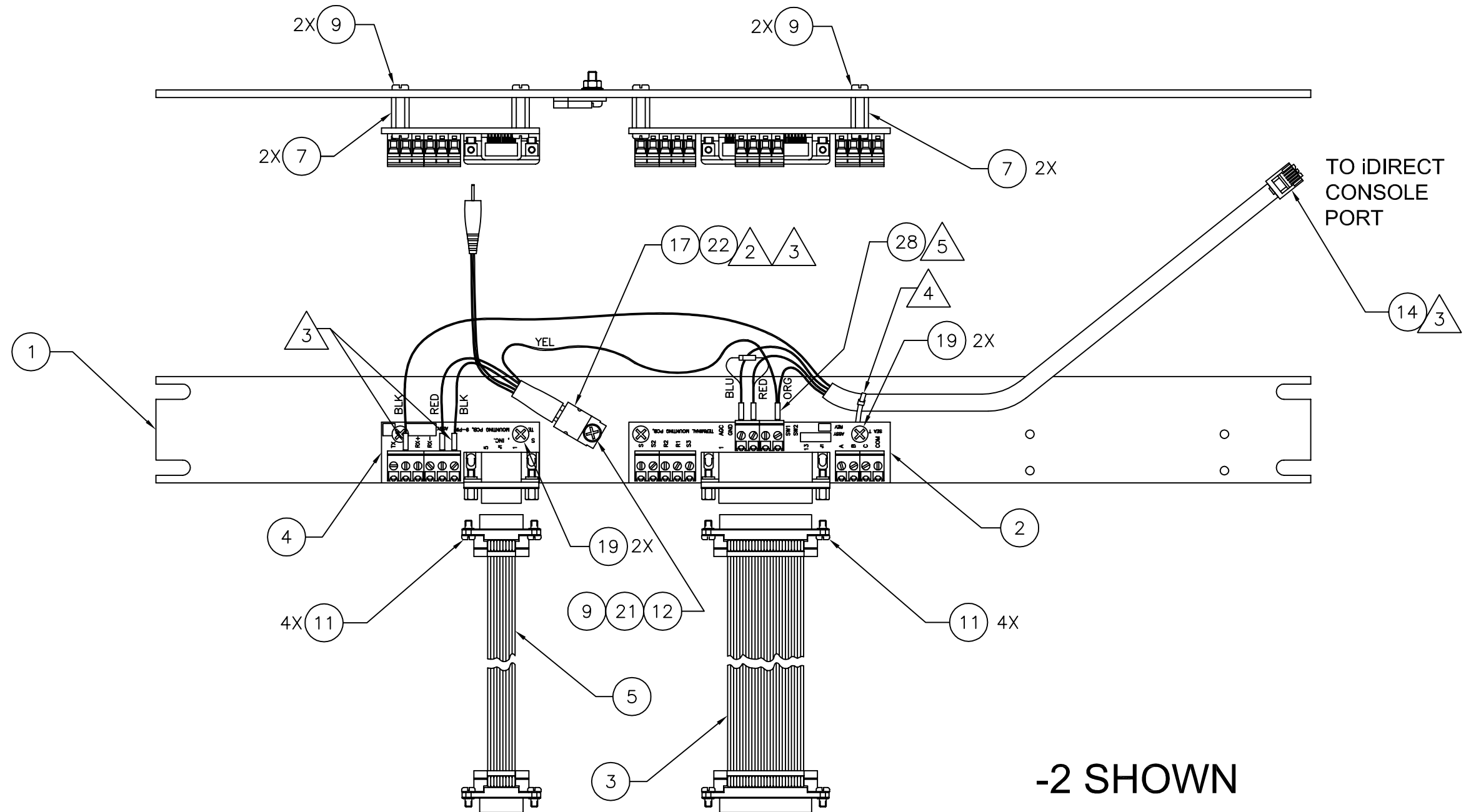

-2 SHOWN

SIZE B	SCALE: 1/2	DRAWING NUMBER: 121628	REV: L
SHEET NUMBER:			2 of 4

NOTES (UNLESS OTHERWISE SPECIFIED):

1. APPLY ADHESIVE PER SEATEL SPEC. 121730
2. INSERT SIL-PAD, ITEM 22, BETWEEN REGULATOR & TERMINAL MOUNTING STRIP. ROTATE REGULATOR ASS'Y, ITEM 17, TO PROTECT LEADS FROM BREAKING.
3. INSERT TERMINALS ON CABLE (ITEM 14) INTO CONNECTORS ON ITEMS 4 WITH FLAT SIDE OF CRIMP PINS FACING DOWN, AND TIGHTEN CONNECTOR FIRMLY.
4. SECURE RJ45 SERIAL CABLE, ITEM 14, WITH TIE WRAP TO STANDOFF, ITEM 7.
5. -2 AND -3 ONLY, CRIMP END OF YELLOW WIRE (ITEM 17) AND ORANGE WIRE (ITEM 14) WITH PIN TERMINAL ITEM 28.

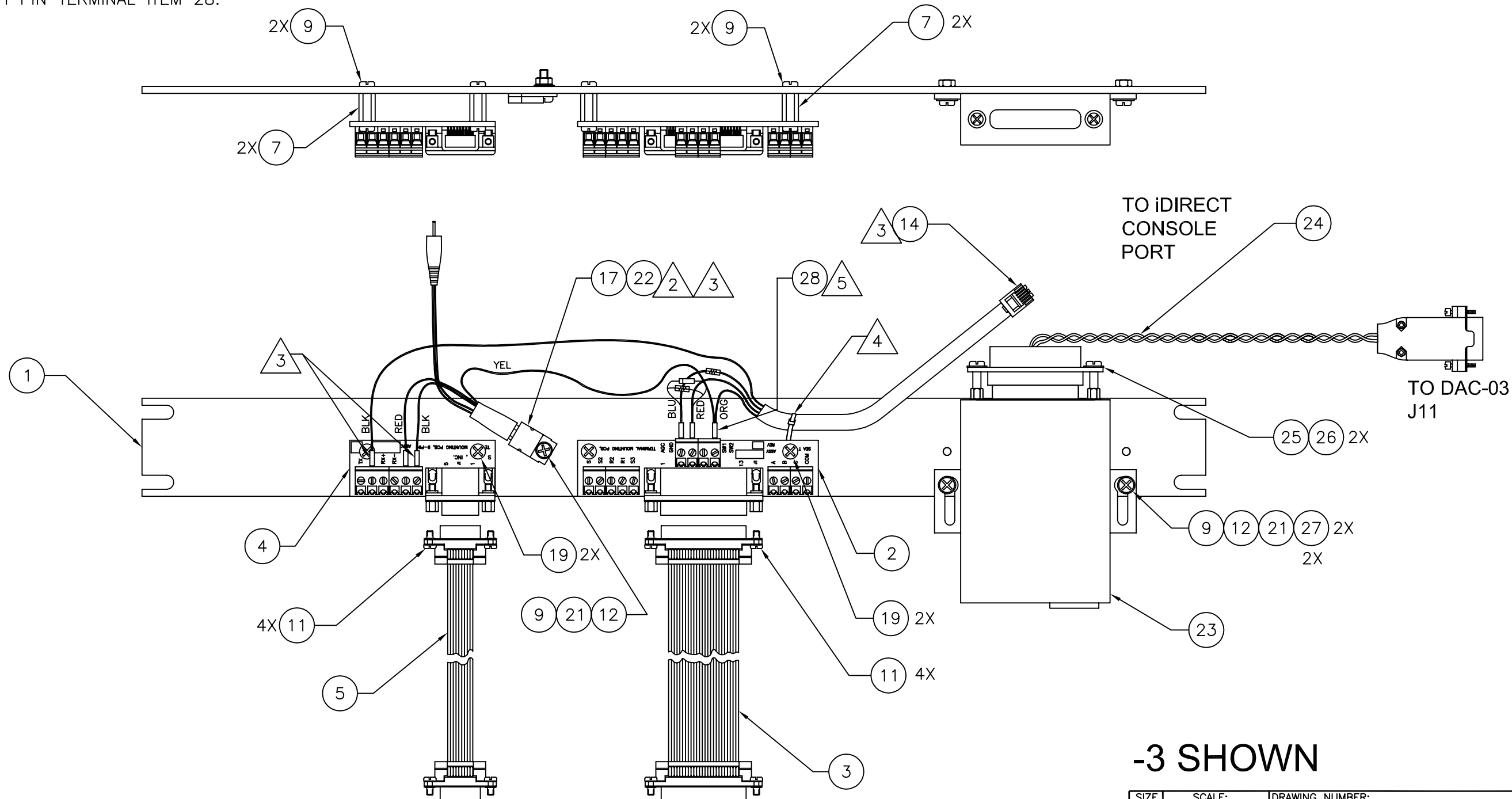

-3 SHOWN

SIZE B	SCALE: 1/2	DRAWING NUMBER: 121628	REV: L
SHEET NUMBER:			3 of 4

NOTES (UNLESS OTHERWISE SPECIFIED):

- 1. APPLY ADHESIVE PER SEATEL SPEC. 121730
- △ 2 N/A IN THIS SHEET
- △ 3 INSERT TERMINALS ON CABLE (ITEM 14) INTO CONNECTORS ON ITEMS 4 WITH FLAT SIDE OF CRIMP PINS FACING DOWN, AND TIGHTEN CONNECTOR FIRMLY.
- △ 4 SECURE RJ45 SERIAL CABLE, ITEM 14, WITH TIE WRAP TO STANDOFF, ITEM 7.
- △ 5 N/A IN THIS SHEET

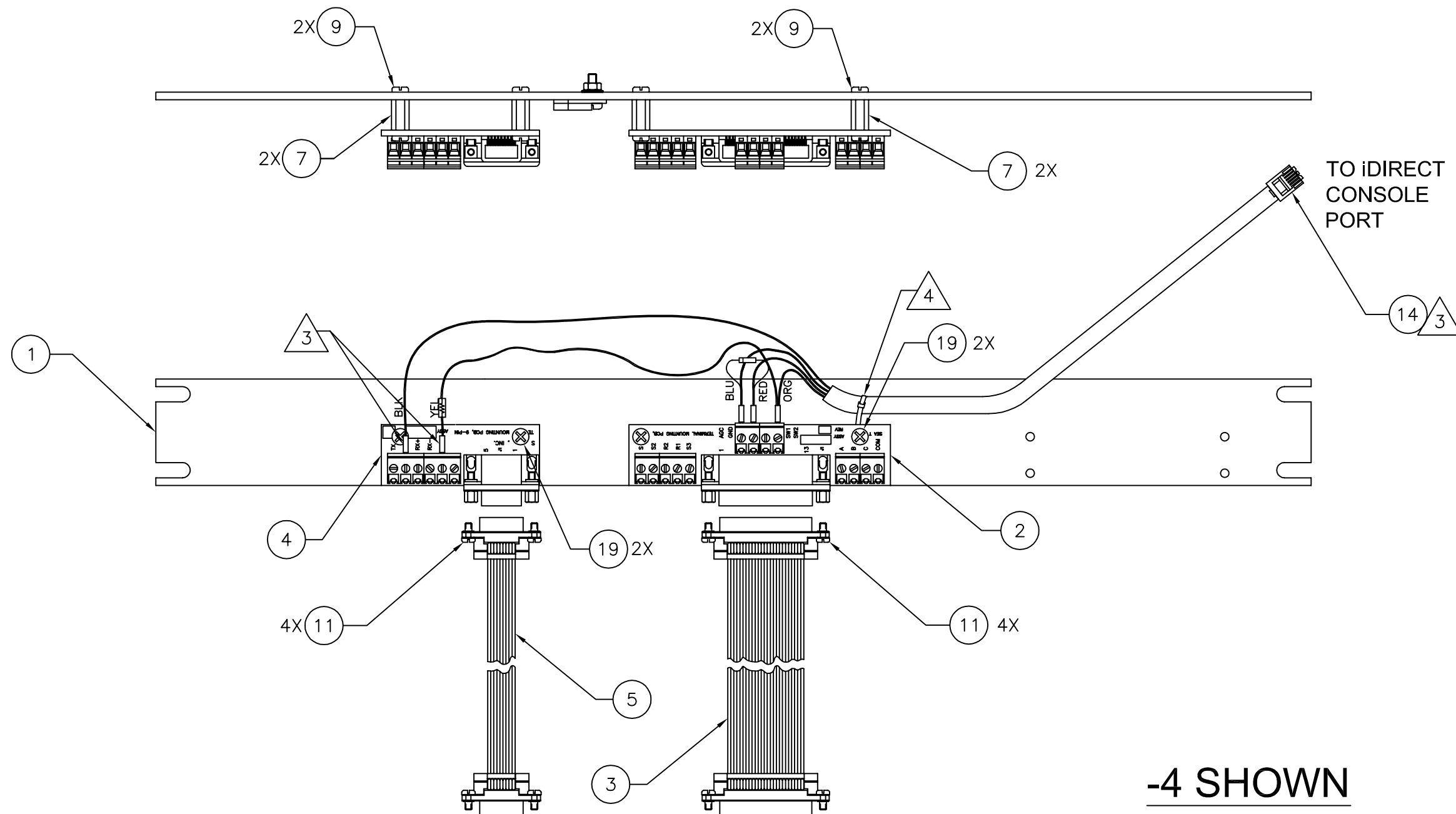

-4 SHOWN

SIZE	SCALE:	DRAWING NUMBER:	REV:
B	1/2	121628	L
SHEET NUMBER:			4 of 4

SINGLE LEVEL MFG BILL OF MATERIAL

FIND	QTY	PART NO	REV	DESCRIPTION	REFERENCE DESIGNATOR
1	1 EA	116880	F	PANEL MACHINING, RACK, BASE MUX	
2	1 EA	117168-2	L1	MODEM ASS'Y, BASE, 3-CH. 75 OHM	
3	1 EA	117611-4	G	MODEM ASS'Y, BASE, 3 CH. -200, 50 OHM	
4	1 EA	116388	D	BRACKET, CONNECTOR	
5	1 EA	115492-1	C1	ADAPTER, N(F)-SMA(F), W/FLANGE	
6	1 EA	110567-19		ADAPTER, N(F)-N(F), STRAIGHT, FLANGE	
7	1 EA	114972-9	L	CABLE ASS'Y, SMA(M) - SMA(M), 6 IN	
8	1 EA	113303-10	S	CABLE ASS'Y, SMA 90 - SMA (M), 8 IN	
10	4 EA	122569-3402	A	STANDOFF, HEX, M/F, 6-32 X .25 OD X 1.25	
11	8 EA	114588-107		SCREW, PAN HD, PHIL, 4-40 x 5/16, S.S.	
12	8 EA	114583-005		NUT, HEX, 4-40, S.S.	
13	2 EA	114588-144		SCREW, PAN HD, PHIL, 6-32 x 1/4, S.S.	
14	6 EA	114580-007		WASHER, FLAT, #6, S.S.	
15	4 EA	114588-146		SCREW, PAN HD, PHIL, 6-32 x 3/8, S.S.	
16	8 EA	114580-005		WASHER, FLAT, #4, S.S.	

				
MUX RACK PANEL ASS'Y, RX SS, SF, TX (N/N)				
PROD FAMILY COMMON	EFF. DATE 20-Nov-07	SHT 1 OF 1	DRAWING NUMBER 116881-16	REV C

NOTES:

1. APPLY ADHESIVE PER SEA TEL SPEC. 121730.

2. ATTACH LABEL INDICATING ASS'Y P/N, REV, AND SYSTEM S/N APPROX. WHERE SHOWN.

REV.	ECO#	DATE	DESCRIPTION	BY
A	N/A	1-14-05	RELEASED TO PRODUCTION.	AMN
B	5003	9-21-05	QTY IN ITEM 14 WS 6.	SL
B1	N/A	11-10-05	ITEM 10 WS 114719-15	SL
C	5598	05-16-07	ITEM 13 WS QTY 6; ITEM 14 WS QTY 2; ITEMS 15 & 16 NEW; ADDED NOTE 2; MOVED NOTES; BENT LEADERS ON BALLOONS	RJW

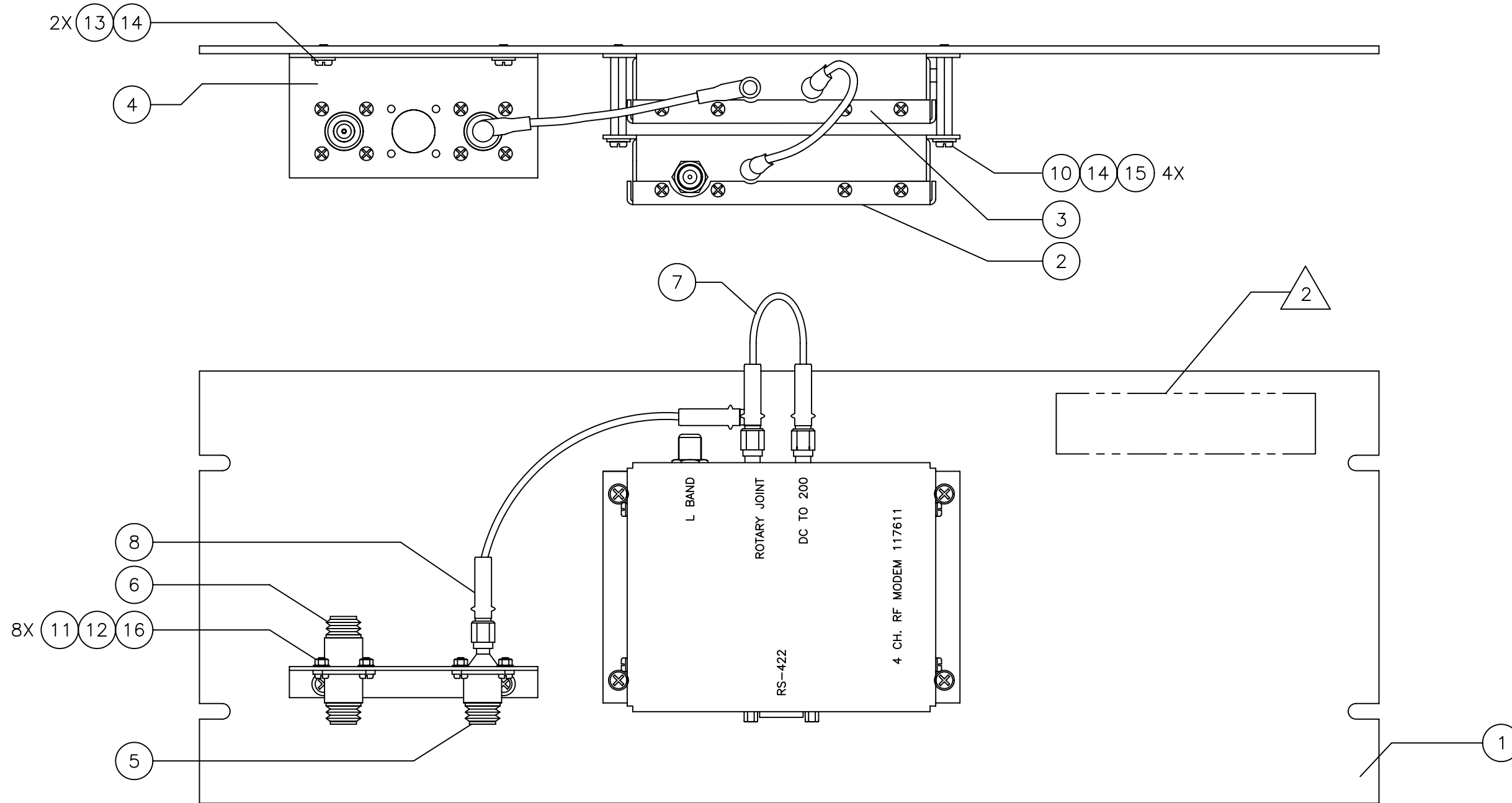

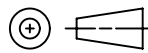
TOLERANCES				
UNLESS OTHERWISE SPECIFIED		SCALE: 1:2	APPROVED BY:	DRAWN BY: MSF
X.X	= ± .050"	DATE: 11-1-04		DRAWING SIZE: B
X.XX	= ± .020"	TITLE: MUX RACK PANEL ASS'Y, RX SS, SF, TX (N/N)		
X.XXX	= ± .005"			
ANGLES	= ± 30'	MODEL:	SHEET: 1 OF 1	DRAWING NUMBER: 116881-16
3rd ANGLE PROJECTION 				REVISION: C